

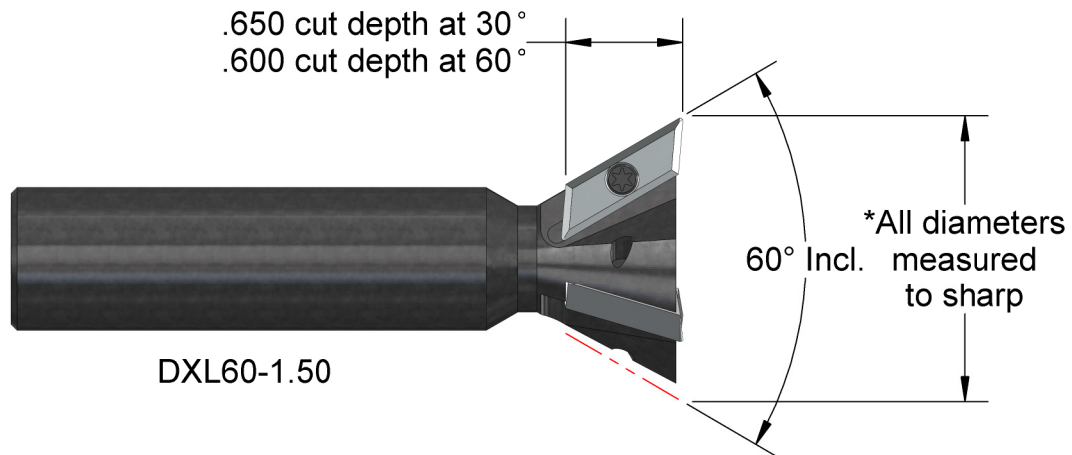



# The Dexi-Dovetail Long Inserts



Number	*Dia.	Cut Depth	Incl. Angle	Shank & Overall	Flutes	Price
DXL20-1.25	1-1/4	.650	20°	3/4 X 3.5	3	\$265.
DXL30-1.25	1-1/4	.640	30°	3/4 X 3.5	3	\$265.
DXL30-1.312	1-5/16	.640	30°	3/4 X 3.5	3	\$270.
DXL30-1.37	1-3/8	.640	30°	3/4 X 3.5	3	\$275.
DXL30-2.0	2.0	.640	30°	1 X 3.88	5	\$395.
DXL40-1.50	1-1/2	.650	40°	3/4 X 3.5	3	\$285.
DXL50-1.50	1-1/2	.620	50°	3/4 X 3.5	3	\$285.
DXL50-2.0	2.0	.620	50°	1 X 4.0	4	\$375.
DXL60-1.50	1-1/2	.600	60°	3/4 X 3.5	3	\$285.
DXL60-1.62	1-5/8	.600	60°	3/4 X 3.5	3	\$300.
DXL60-2.0	2.0	.600	60°	1 X 3.88	4	\$395.
DXL60-3.0	3.0	.600	60°	1-1/4 X 4.5	6	\$575.

Long Insert 	Insert Number	Radius	Price	
			No-Coat	AlTiN
	Di60L-1	.015		
	Di60L-2	.030	\$13.75	\$16.25
	Di60L-3	.046		

Screw & Key	Number	Price
	DX-3MM	\$2.50
	T8	\$6.00

*We use all these cutters in production, milling (38Rc) 4340 at 1100 to 1800 RPM and .001 to .002 IPT.*



A. B. TOOLS, INC.  
1051 Aviation Blvd.  
Lincoln, CA 95648-9312

Phone 916 408-2442  
FAX 916 993-3949

www.abtoolsinc.com  
E-Mail: mail@abtoolsinc.com