

Solid Carbide Corner Rounders

CNC Profile Ground, Double End

The Major Cut Dia. equals
the Minor Dia. + (R. X 2) + .020

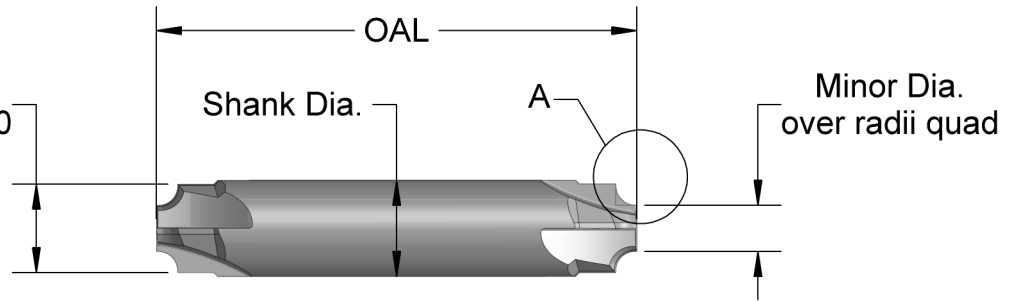

**Special Corner Rounders
in 4-6 working days**
Machining what part
material, please?

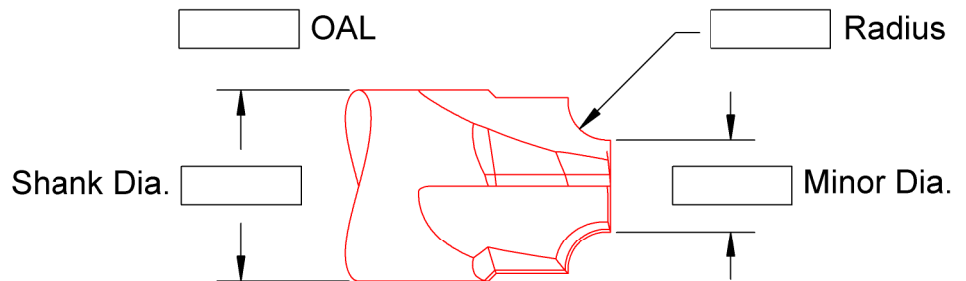
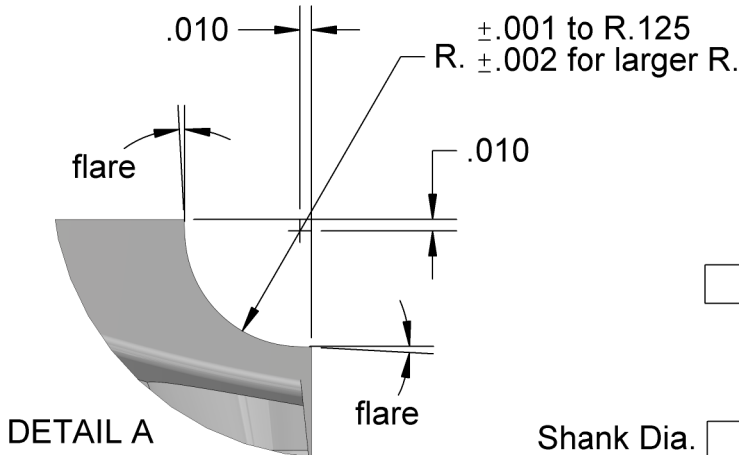

All AB Tools corner rounders
are made with these features
to avoid gouging.

Tool No.	(add R. to prefix, example CR12-031) Radius Sizes Available	Minor Dia.	No. Flutes	Shank & OAL	Prices	
					No-Coat	AlTiN
CR1-___	.010 .013 .015 .018 .020 .022 .025 .028 .031			3/8 x 2.5	\$95.	\$109.
	.035 .038 .040 .046 .048 .050 .055					
CR2-___	.062 .070 .078 .080 .085 .093 .098 .100 .109 .118 .120 .125	.240	4	1/2 x 2.5	\$115.	\$133.
	.140 .156 .170 .187			5/8 x 3.5	\$180.	\$206.
	.197 .203 .218 .234 .250			3/4 x 4.0	\$215.	\$245.
CR03-___	.010 .015 .020 .025 .031 .040 .046 .050 .055	.030	2	3/16 x 2	\$60.	\$67.
	.062 .070 .078					
CR06-___	.010 .013 .015 .018 .020 .022 .025 .028 .031 .035 .040	.060	2	3/16 x 2	\$60.	\$67.
	.046 .048 .050 .055 .060					
CR12-___	.010 .013 .015 .018 .020 .022 .025 .028 .031	.120	2	1/4 x 2	\$70.	\$78.
	.035 .038 .040 .046 .048 .050 .055 .060					
CR18-___	.015 .020 .031 .035 .046 .055 .062 .070 .078 .080	.180	3	3/8 x 2.5	\$95.	\$109.
	.085 .093 .098 .109 .118 .120 .125 .130 .135 .140 .150 .156			1/2 x 2.5	\$115.	\$133.
	.170 .180 .187 .197 .203 .218			5/8 x 3.5	\$180.	\$206.
	.234 .250			3/4 x 4.0	\$215.	\$245.



A. B. TOOLS, INC.
1051 Aviation Blvd.
Lincoln, CA 95648-9312

Phone 916 408-2442
FAX 916 993-3949

www.abtoolsinc.com
E-Mail: mail@abtoolsinc.com