

Solid Carbide Dovetail Cutters for O-Ring Grooves WITHOUT Drop Hole Provision

NUMBER	O-RING SIZE	PART Ø TSC	NECK Ø OVER R	SLOT DEPTH	TOP RAD.	BOTTOM RAD.	NO. OF FLUTES	PRICE	AITiN
DTNDH1/16	.070	.057	.036	.051	.005	.015	1	\$68.	\$72.
DTNDH3/32	.103	.085	.048	.082	.010	.015	1	\$68.	\$72.
DTNDH1/8	.139	.115	.0685	.112	.010	.031	2	\$75.	\$79.
DTNDH3/16	.210	.173	.0835	.172	.015	.031	2	\$85.	\$90.
DTNDH1/4	.275	.233	.1235	.232	.015	.062	2	\$100.	\$107.
DTNDH3/8	.375	.317	.178	.317	.020	.094	3	\$130.	\$137.

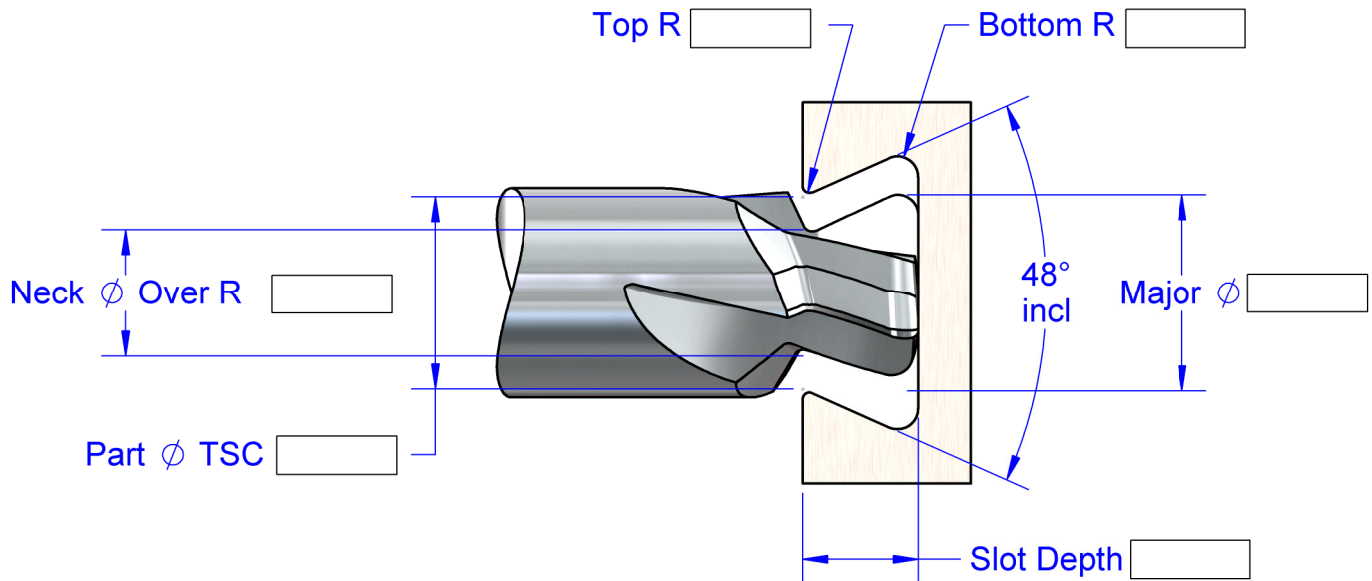

Reference Chart

NUMBER	MAJOR Ø	SHANK Ø	OAL
DTNDH1/16	.060	3/16	2
DTNDH3/32	.094	3/16	2
DTNDH1/8	.124	3/16	2
DTNDH3/16	.187	1/4	2
DTNDH1/4	.247	5/16	2.5
DTNDH3/8	.337	3/8	2.5

**Specials in 4-6
Working Days**



A. B. TOOLS, INC.
1051 Aviation Blvd.
Lincoln, CA 95648-9312

Phone 916 408-2442
FAX 916 993-3949

www.abtoolsinc.com
E-Mail: mail@abtoolsinc.com