

# A.B. Tools, Inc.

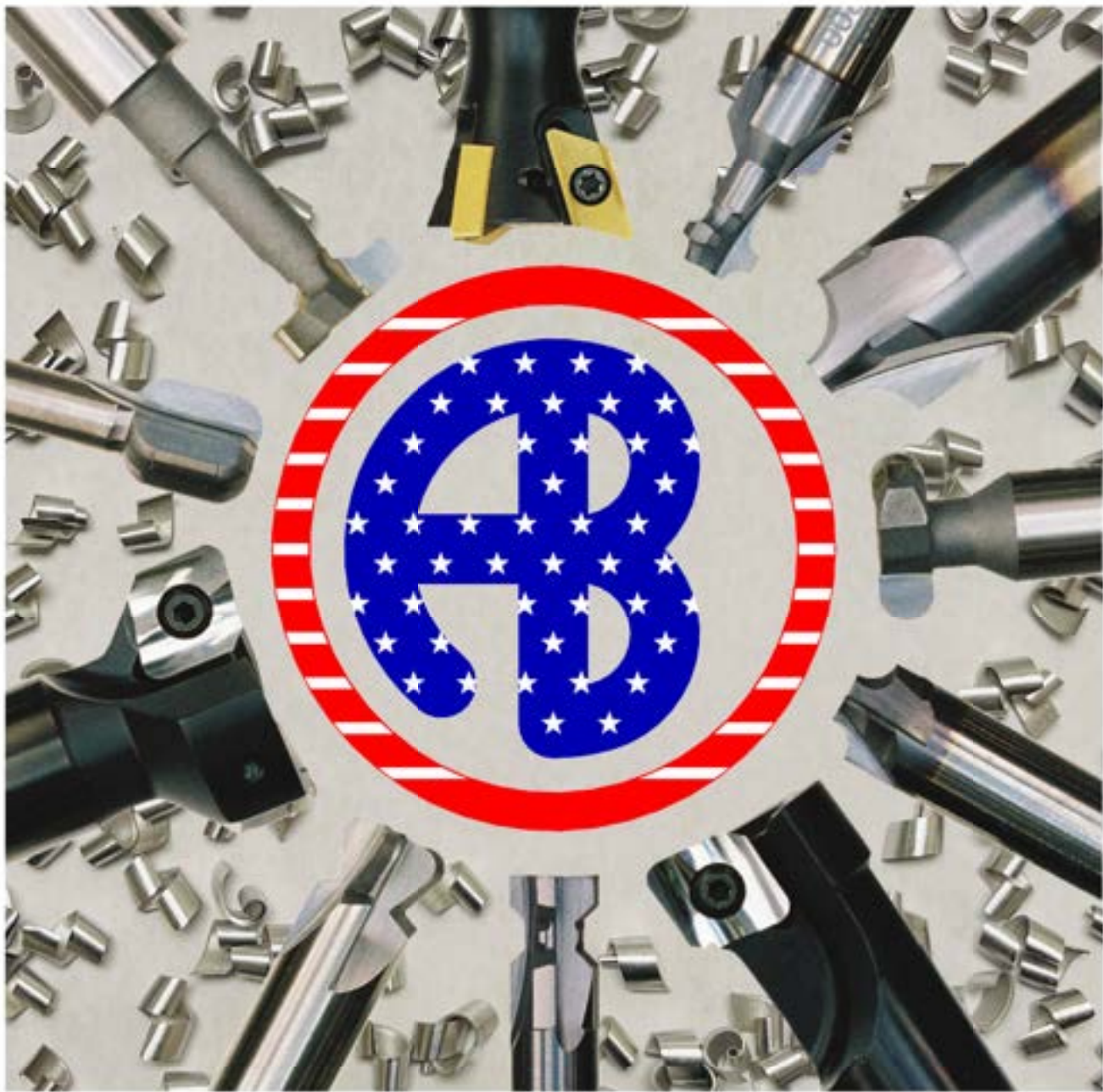

Made in the USA since 1977

1051 Aviation Blvd.  
Lincoln, CA 95648-9312  
(916) 408-2442 FAX (916) 993-3949  
[www.abtoolsinc.com](http://www.abtoolsinc.com)  
E-Mail: [mail@abtoolsinc.com](mailto:mail@abtoolsinc.com)

New Products →

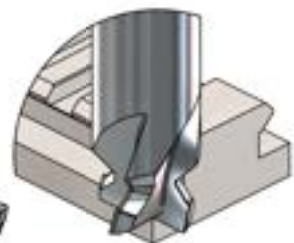

# Table of Contents

Page	Description
1.	Table of Contents
2.	Table of Contents
3.	Keyseat Cutters, Carbide Tipped
4.	Keyseat Cutters, Extra Long, Carbide Tipped
5.	Keyseat Cutters, Smaller Dia., Solid Carbide
6.	Keyseat Cutters, Larger Dia., Solid Carbide
7.	Keyway Cutters, Standard, Solid Carbide
8.	Keyway Cutters, Standard, Carbide Tipped
9.	T-Slot Cutters, Standard, Carbide Tipped - <b>New</b>
10.	Keyseat Cutters, Extra Long, Solid Carbide - <b>New</b>
11.	Slotting Tools, Reduced Shank, Solid Carbide - <b>New</b>
12.	Picatinny Rail Cutters
13.	Picatinny, Male Fixture, Cutters
14.	Picatinny Slot & Chamfer End Mill
15.	Keymod Cutter
16.	Charging Handle Slot Cutter
17.	O-Ring Dovetail Cutters, Inch
18.	O-Ring Dovetail Cutters, Metric
19.	O-Ring Dovetail Cutters, Without Drop Hole
20.	O-Ring Dovetail Cutters, Half Dovetail
21.	O-Ring Dovetail Cutters, Specials
22.	O-Ring Dovetail Lathe Tools
23.	Cable Groove, DSP, Dovetail Cutters
24.	Dovetail Cutters, Solid Carbide, Ø1/8" to Ø1/4"
25.	Dovetail Cutters, Solid Carbide, Ø3/8" to Ø5/8"
26.	Corner Rounders, Solid Carbide (smaller radii)
27.	Corner Rounders, Extended Reach, Solid Carbide
28.	Corner Rounders, Top & Bottom
29.	Back Corner Rounders
30.	Full Concave Radius Cutters
31.	Corner Rounders, Carbide Tipped (med. radii)
32.	Corner Rounders, M42 Cobalt (larger radii)
33.	Thread Mills, Solid Carbide
34.	Thread Mills, ACME, Solid Carbide - <b>New</b>
35.	Thread Relief Mills, Solid Carbide



A. B. TOOLS, INC.  
1051 Aviation Blvd.  
Lincoln, CA 95648-9312

Phone 916 408-2442  
FAX 916 993-3949

www.abtoolsinc.com  
E-Mail: mail@abtoolsinc.com

# Table of Contents

Page	Description
36.	Bevel Cutters, Solid Carbide
37.	Top & Bottom Chamfer Cutters
38.	Chamfer End Mills, Solid Carbide
39.	Taper End Mills, Solid Carbide
40.	Lollipop Undercut End Mills - <b>New</b>
41.	End Mills, Reduced Shank, Solid Carbide - <b>New</b>
42.	Top Hat Removal Tool - <b>New</b>
43.	Angle & Shank Flat Reference
44.	Dovetail Cutters, Solid Carbide, Ø.75" to Ø1.5" - <b>New</b>
45.	Dovetail Cutters, Carbide tipped
46.	Dexi-Dovetails, 10° to 60°, Short Inserts
47.	Dexi-Dovetails, 20° to 60°, Long Inserts
48.	Dexi-Dovetails, 70° to 90°, Original Inserts
49.	Dexi-Dovetails, 70° to 90°, Wider Inserts - <b>New</b>
50.	End Mills, Indexable - <b>New</b>
51.	Chamfer Cutters, Indexable - <b>New</b>
52.	Back Chamfer Cutters, Indexable - <b>New</b>
53.	Spot-Dex Tools
54.	Chamfer Hogs, Single Flute
55.	Chamfer Hogs, Positive Rake
56.	Chamfer Hogs, Negative Rake
57.	Weldon & Linear Flat Tools
58.	Saw Arbors
59.	Accu-Holds, Inch
60.	Accu-Holds, Metric
61.	Accu-Holds, MMH, All Metric - <b>New</b>
62.	Aluma-Hogs
63.	Aluminum Milling Tests
64.	Shell Mill Arbors - <b>New</b>
65.	Shear-Hogs, Shell
66.	Shear-Hogs, T-Slot
67.	Shear-Hogs, Shank Style (back cover)



A. B. TOOLS, INC.  
1051 Aviation Blvd.  
Lincoln, CA 95648-9312

Phone 916 408-2442  
FAX 916 993-3949

www.abtoolsinc.com  
E-Mail: mail@abtoolsinc.com

# Carbide Tipped Keyseat Cutters with your decimal width in 4-6 working days

Machining what part material, please? \_\_\_\_\_

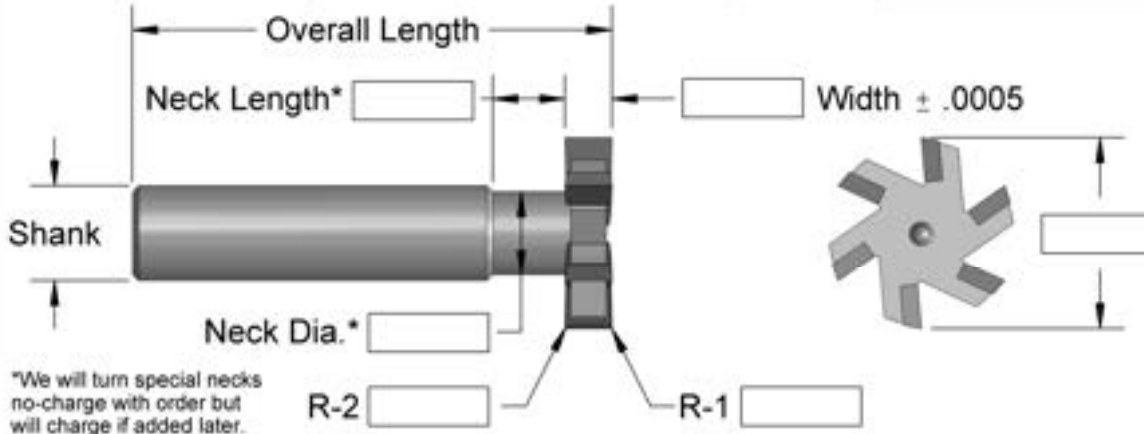

Diameters to plus .015 unless you request otherwise

\*We will turn special necks no-charge with order but will charge if added later.

Diameter Plus .015 Minus Zero	Width Range	Basic Cutter Prices				Shank & Overall Length
		For Aluminum Flutes	Price	For Ferrous Flutes	Price	
5/8	.065/.190	2	\$90.	5	\$115.	1/2 Shank 2.5 OAL
3/4	.065/.220	2	\$95.	5	\$115.	
7/8	.075/.255	2	\$105.	6	\$120.	
1	.085/.315	2	\$110.	6	\$125.	
1-1/8	.110/.315	2	\$115.	6	\$145.	
1-1/4	.110/.350	3	\$120.	8	\$160.	
1-3/8	.110/.380	3	\$130.	8	\$165.	

For Minor Modifications add to your basic price:

1 CHAMFER \$35.  
2 CHAMFERS \$50.

1 RADIUS \$40.  
2 RADII \$60.  
FULL RADIUS \$60.

1-1/2	.110/.374	3	\$150.	8	\$190.	3/4 Shank 3.5 OAL
1-1/2	.375/.505	3	\$185.	8	\$225.	
1-3/4	.120/.374	4	\$175.	10	\$220.	
1-3/4	.375/.505	4	\$200.	10	\$245.	
2	.120/.374	4	\$205.	12	\$260.	
2	.375/.505	4	\$245.	12	\$295.	
2-1/4	.120/.374	4	\$225.	12	\$295.	
2-1/4	.375/.505	4	\$260.	12	\$325.	
2-1/2	.120/.374	6	\$245.	12	\$320.	
2-1/2	.375/.505	6	\$285.	12	\$365.	

Staggered tooth cutters add 30% to basic price  
(2) piece minimum

Slot plus top Chamfers Upon Request

Suggested Starting Data:  
Ferrous 150-250 SFM; .001/.003 IPT, Non-Ferrous 1K-3K SFM; .002/.006 IPT



A. B. TOOLS, INC.  
1051 Aviation Blvd.  
Lincoln, CA 95648-9312

Phone 916 408-2442  
FAX 916 993-3949

www.abtoolsinc.com  
E-Mail: mail@abtoolsinc.com

# Extra Long Carbide Tipped Keyseat Cutters with your decimal width in 4-6 working days

Machining what part material, please? \_\_\_\_\_

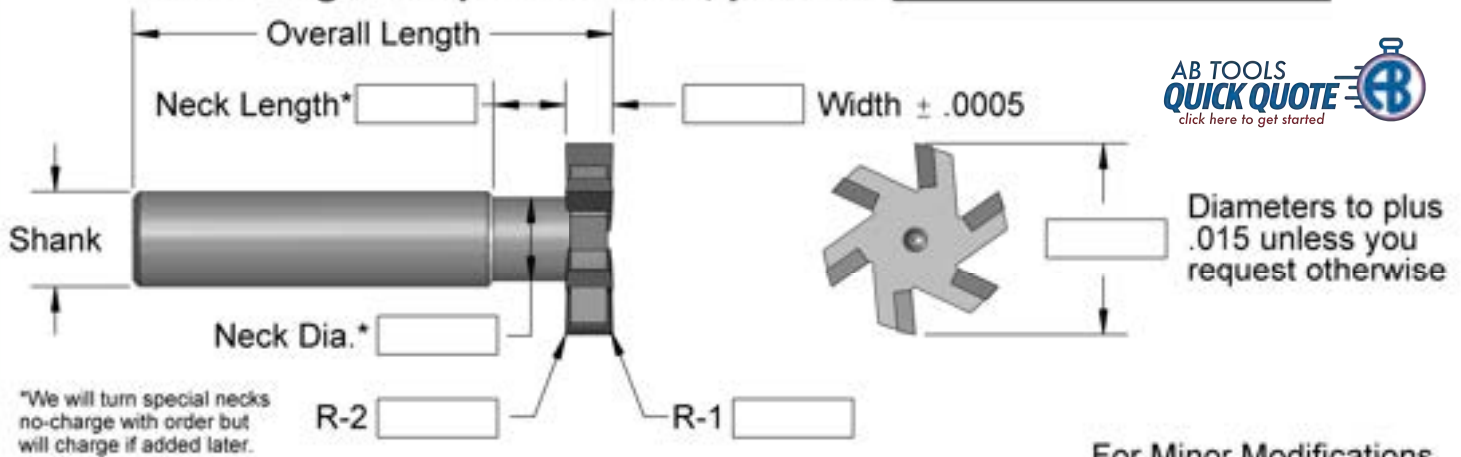

\*We will turn special necks no-charge with order but will charge if added later.

Diameter Plus .015 Minus Zero	Width Range	Basic Cutter Prices				Shank & Overall Length
		For Aluminum Flutes	Price	For Ferrous Flutes	Price	
5/8	.065/.190	2	\$145.	5	\$160.	1/2 Shank 4.5 OAL
3/4	.065/.220	2	\$145.	5	\$160.	
7/8	.075/.255	2	\$155.	6	\$165.	
1	.085/.315	2	\$160.	6	\$175.	
1-1/8	.110/.315	2	\$165.	6	\$195.	
1-1/4	.110/.350	3	\$175.	8	\$210.	
1-3/8	.110/.380	3	\$185.	8	\$220.	

For Minor Modifications add to your basic price.



1 CHAMFER \$35.  
2 CHAMFERS \$50.



1 RADIUS \$40.  
2 RADII \$60.  
FULL RADIUS \$60.

1-1/2	.110/.374	3	\$210.	8	\$250.	3/4 Shank 6.0 OAL
1-1/2	.375/.505	3	\$245.	8	\$290.	
1-3/4	.120/.374	4	\$230.	10	\$285.	
1-3/4	.375/.505	4	\$265.	10	\$315.	
2	.120/.374	4	\$275.	12	\$325.	
2	.375/.505	4	\$305.	12	\$375.	
2-1/4	.120/.374	4	\$295.	12	\$375.	
2-1/4	.375/.505	4	\$335.	12	\$430.	
2-1/2	.120/.374	6	\$325.	12	\$415.	
2-1/2	.375/.505	6	\$340.	12	\$450.	



Staggered tooth Cutters add 30% to basic price  
(2) piece minimum



Slot plus top Chamfers Upon Request

Suggested Starting Data:  
Ferrous 150-250 SFM; .001/.003 IPT, Non-Ferrous 1K-3K SFM; .002/.006 IPT



A. B. TOOLS, INC.  
1051 Aviation Blvd.  
Lincoln, CA 95648-9312

Phone 916 408-2442  
FAX 916 993-3949

www.abtoolsinc.com  
E-Mail: mail@abtoolsinc.com

# Solid Carbide Slotting (Keyseat) Cutters .625 diameter and smaller your decimal width in 4-6 working days

Machining what part material, please? \_\_\_\_\_

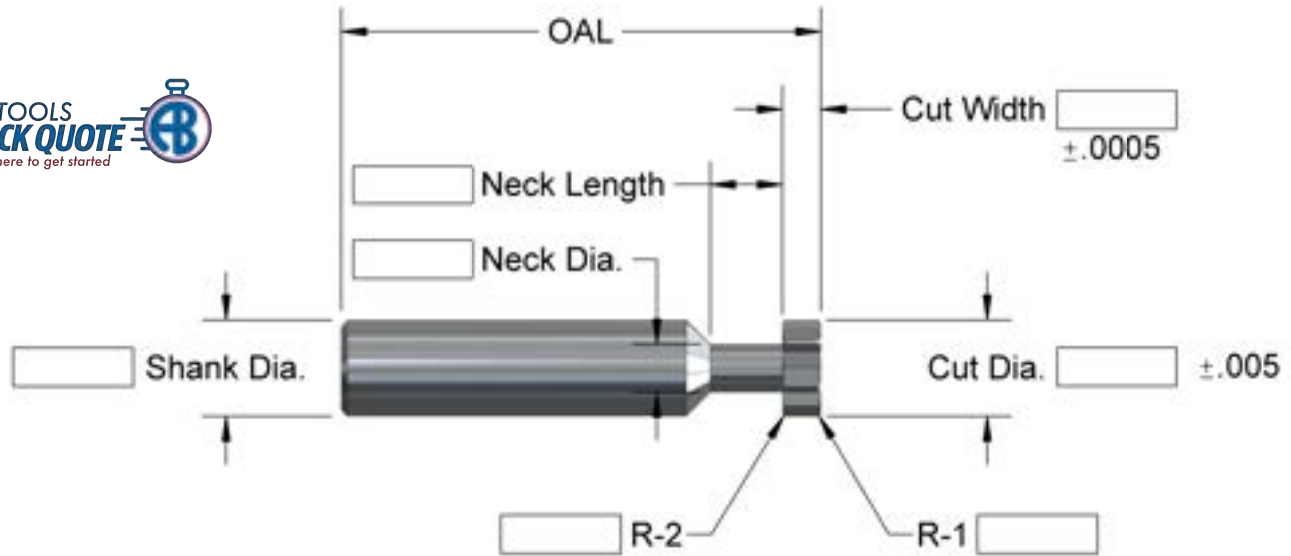

*Suggested starting data:*  
 Ferrous 150 to 300 SFM; .001/.003 IPT  
 Non-Ferrous 1K-3K SFM; .002/.006 IPT  
 For thin or weak necked cutters, .0005 IPT

Number of flutes is your choice based on feasibility. We suggest coarse for non-ferrous, medium for titanium/stainless & maximum for cast iron and tough materials.

Out Diameter	Shank & OAL	Basic Price
.030/.060	3/16 X 2	\$105.
.062/.186	3/16 X 2	\$90.
.188/.248	1/4 X 2	\$95.
.250/.390	3/8 X 2.5	\$105.
.400/.515	1/2 X 2.5	\$115.
.515/.625	5/8 X 3	\$135.

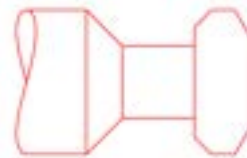

One Chamfer \$35.  
Two Chamfers \$50.

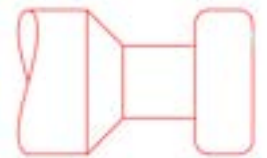

One Radius \$40.  
Two Radii \$60.  
Full Radius \$60.

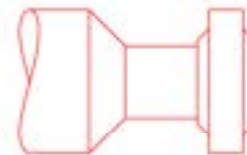

Slot plus top Chamfers  
Upon Request

Add above prices to the basic price for minor modifications.



A. B. TOOLS, INC.  
1051 Aviation Blvd.  
Lincoln, CA 95648-9312

Phone 916 408-2442  
FAX 916 993-3949

www.abtoolsinc.com  
E-Mail: mail@abtoolsinc.com

# Solid Carbide Slotting (Keyseat) Cutters from .530 to 2.0 diameters

**your decimal width in 4-6 working days**

Machining what part material, please? \_\_\_\_\_

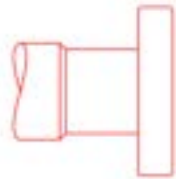
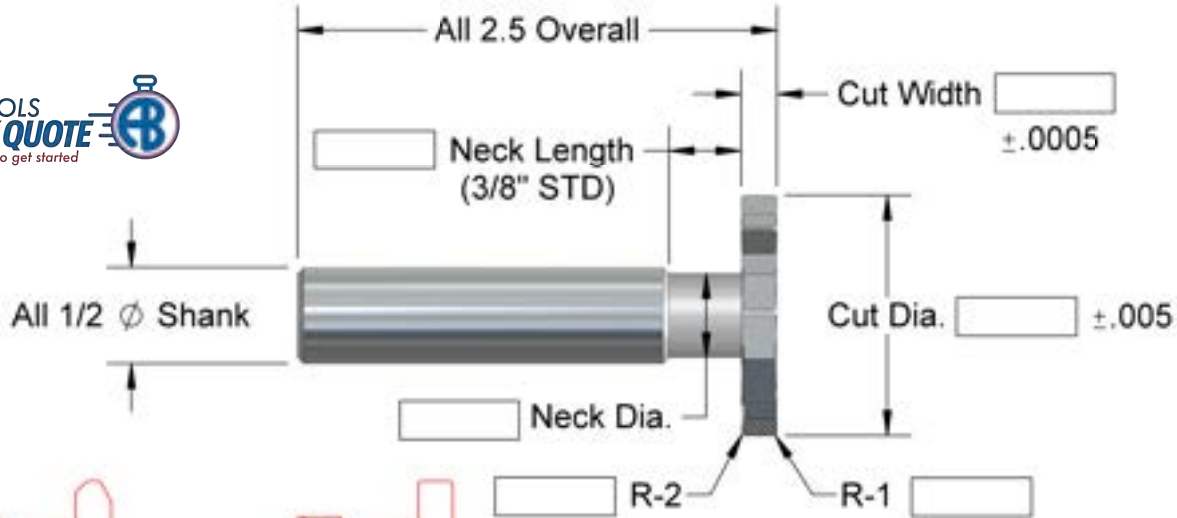

Necks can be modified at no extra charge if feasible.

One Chamfer \$35.  
Two Chamfers \$50.

One Radius \$40.  
Two Radii \$60.  
Full Radius \$60.

*Suggested starting data:*  
Ferrous 150 to 300 SFM; .001/.003 IPT  
Non-Ferrous 1K-3K SFM; .002/.006 IPT  
For thin or weak necked cutters, .0005 IPT

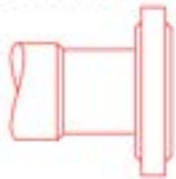

Slot plus top Chamfers  
Upon Request

Number of flutes is your choice based on feasibility. We suggest coarse for non-ferrous, medium for titanium/stainless & maximum for cast iron and tough materials.

Cut Dia.	Max. no. of Flutes	As-Cast Neck Dia.	Basic Prices for .020 thru .135 Widths	Basic Prices for .136 thru .260 Widths	Basic Prices for .261 thru .374 Widths	Basic Prices for .375 thru .440 Widths
.625	8	3/8	\$160.	\$170.	\$175.	
.750	10	7/16	\$165.	\$175.	\$180.	
1.00	12	7/16	\$175.	\$185.	\$190.	
1.25	14	7/16	\$185.	\$195.	\$220.	\$280.
1.50	16	7/16	\$200.	\$220.	\$260.	\$295.
1.75	18	15/32	\$230.	\$250.	\$290.	\$345.
2.00	20	15/32	\$260.	\$275.	\$310.	\$365.



A. B. TOOLS, INC.  
1051 Aviation Blvd.  
Lincoln, CA 95648-9312

Phone 916 408-2442  
FAX 916 993-3949

www.abtoolsinc.com  
E-Mail: mail@abtoolsinc.com

# Standard Keyway Cutters Solid Carbide

**Specials in 4-6  
Working Days**

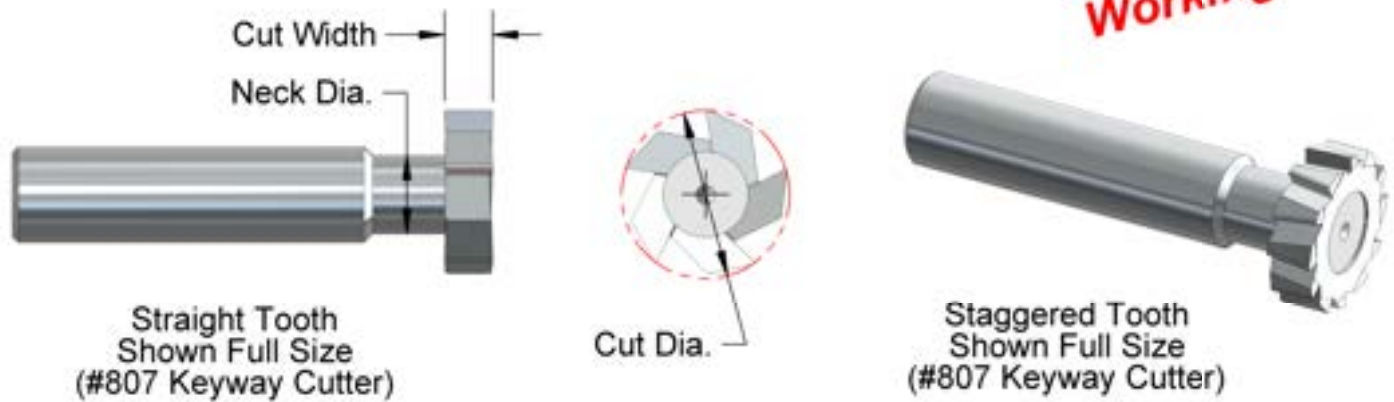

Straight Tooth  
Shown Full Size  
(#807 Keyway Cutter)

Staggered Tooth  
Shown Full Size  
(#807 Keyway Cutter)

All shanks are 1/2" Dia. and 2-1/2" overall

Ind. Std. #	Cut Dia.	Cut Width	Neck Dia.	Neck Length	No. of Flutes Aluminum	No. of Flutes Steel	No. of Flutes Staggered	Price	
								Straight Tooth	Staggered Tooth
202	1/4	1/16	.064	.090	3	6	6	\$85.	\$100.
202.5	5/16	1/16	.065	.090	3	6	6	\$85.	\$100.
302.5	5/16	3/32	.096	.150	3	6	6	\$85.	\$100.
203	3/8	1/16	.209	.125	3	6	6	\$95.	\$110.
303	3/8	3/32	.146	.180	3	6	6	\$95.	\$110.
403	3/8	1/8	.090	.180	3	6	6	\$95.	\$110.
204	1/2	1/16	.140	.090	3	8	8	\$105.	\$120.
304	1/2	3/32	.160	.180	3	8	8	\$105.	\$120.
404	1/2	1/8	.190	.250	3	8	8	\$105.	\$120.
305	5/8	3/32	.190	.150	4	8	8	\$160.	\$176.
405	5/8	1/8	.220	.250	4	8	8	\$160.	\$176.
505	5/8	5/32	.250	.250	4	8	8	\$160.	\$176.
605	5/8	3/16	.280	.280	4	8	8	\$160.	\$176.
406	3/4	1/8	.220	.250	4	10	10	\$165.	\$182.
506	3/4	5/32	.250	.250	4	10	10	\$165.	\$182.
606	3/4	3/16	.280	.280	4	10	10	\$165.	\$182.
806	3/4	1/4	.340	.250	4	10	10	\$165.	\$182.
507	7/8	3/16	.250	.280	5	12	12	\$170.	\$187.
707	7/8	7/32	.310	.250	5	12	12	\$170.	\$187.
807	7/8	1/4	.340	.250	5	12	12	\$170.	\$187.



A. B. TOOLS, INC.  
1051 Aviation Blvd.  
Lincoln, CA 95648-9312

Phone 916 408-2442  
FAX 916 993-3949

www.abtoolsinc.com  
E-Mail: mail@abtoolsinc.com



# Standard Keyway Cutters Carbide Tipped

**Specials in 4-6  
Working Days**

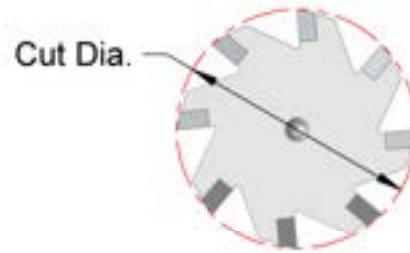
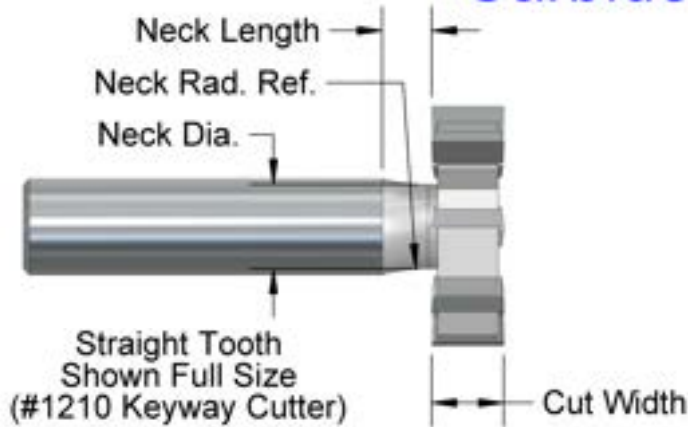

All shanks are 1/2" Dia. and 2-1/2" overall

Ind. Std. #	Cut Dia.	Cut Width	Neck Dia.	Neck Length	Neck Rad. Ref.	No. of Flts.	Price	
							Straight Tooth	Staggered Tooth
608	1	3/16	.280	.440	.85	6	<b>\$115.</b>	<b>\$150.</b>
708	1	7/32	.310	.415	.865			
808	1	1/4	.340	.385	.880			
1008	1	5/16	.375	.219	N/A			
1208	1	3/8	.410	.219	N/A			
609	1-1/8	3/16	.310	.410	.855	6	<b>\$130.</b>	<b>\$165.</b>
709	1-1/8	7/32	.340	.380	.875			
809	1-1/8	1/4	.380	.346	.895			
1009	1-1/8	5/16	.435	.250	N/A			
610	1-1/4	3/16	.310	.410	.855	8	<b>\$145.</b>	<b>\$185.</b>
710	1-1/4	7/32	.340	.380	.875			
810	1-1/4	1/4	.375	.350	.895			
1010	1-1/4	5/16	.485	.250	N/A			
1210	1-1/4	3/8	.485	.250	N/A			
811	1-3/8	1/4	.400	.310	.930	8	<b>\$150.</b>	<b>\$190.</b>
1011	1-3/8	5/16	.485	.313	N/A			
1211	1-3/8	3/8	.485	.313	N/A			
812	1-1/2	1/4	.430	.310	N/A	8	<b>\$170.</b>	<b>\$210.</b>
1012	1-1/2	5/16	.490	.250	N/A			
1212	1-1/2	3/8	.490	.250	N/A			



Staggered Tooth  
Shown Full Size  
(#1210 Keyway Cutter)



Staggered Tooth  
All Ends Cut  
Shown Full Size  
(#1210 Keyway Cutter)



A. B. TOOLS, INC.  
1051 Aviation Blvd.  
Lincoln, CA 95648-9312

Phone 916 408-2442  
FAX 916 993-3949

www.abtoolsinc.com  
E-Mail: mail@abtoolsinc.com

# NEW! Carbide Tipped T-Slot cutters Industry Standard Stagger Tooth NEW!

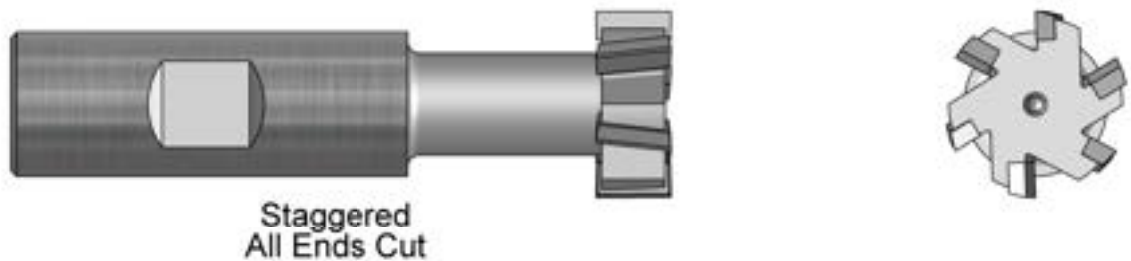
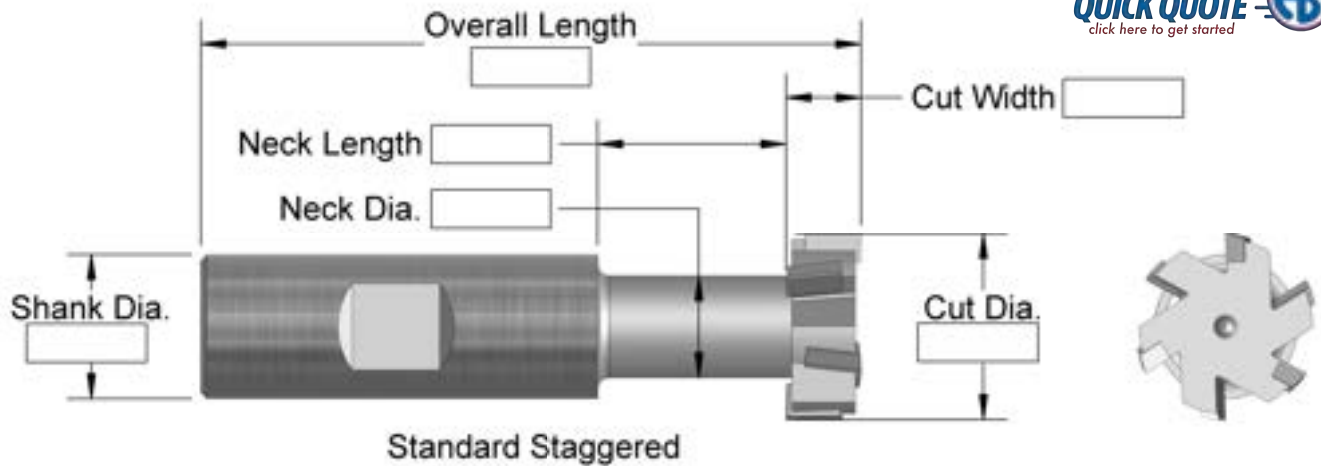

Number	Bolt Size	Cut Dia	Cut Width	Neck Dia.	Neck Length	Shank Dia.	OAL	No. of Flutes	Price	
									Standard	All Ends Cut
TSKS-1/4*	1/4"	.531	.234	.256	.55	1/2"	2-1/2	6	\$150.	\$157.
TSKT-5/16	5/16"	.656	.265	.330	.61	1/2"	2.69	6	\$135.	\$142.
TSKT-3/8	3/8"	.781	.328	.410	.86	3/4"	3.25	6	\$165.	\$173.
TSKT-1/2	1/2"	.968	.390	.530	.98	3/4"	3.44	6	\$175.	\$184.
TSKT-5/8	5/8"	1.250	.484	.660	1.14	1"	3.94	6	\$215.	\$226.
TSKT-3/4	3/4"	1.468	.625	.780	1.50	1"	4.44	8	\$245.	\$257.
TSKT-1.0	1"	1.844	.828	1.030	1.67	1-1/4"	4.81	8	\$315.	\$330.
TSKT-1-1/4	1-1/4"	2.219	1.094	1.218	1.97	1-1/4"	5.38	8	\$395.	\$415.
TSKT-1-1/2	1-1/2"	2.656	1.344	-	-	1-1/4"	5.91	8	\$445.	\$467.

\* Noted cutter is solid carbide



A. B. TOOLS, INC.  
1051 Aviation Blvd.  
Lincoln, CA 95648-9312

Phone 916 408-2442  
FAX 916 993-3949

www.abtoolsinc.com  
E-Mail: mail@abtoolsinc.com

# Extra Long Solid Carbide Keyseat Cutters

**NEW !!!** from .530 to 2.0 diameters **NEW !!!**  
with your decimal width in 4-6 working days

Machining what part material, please? \_\_\_\_\_

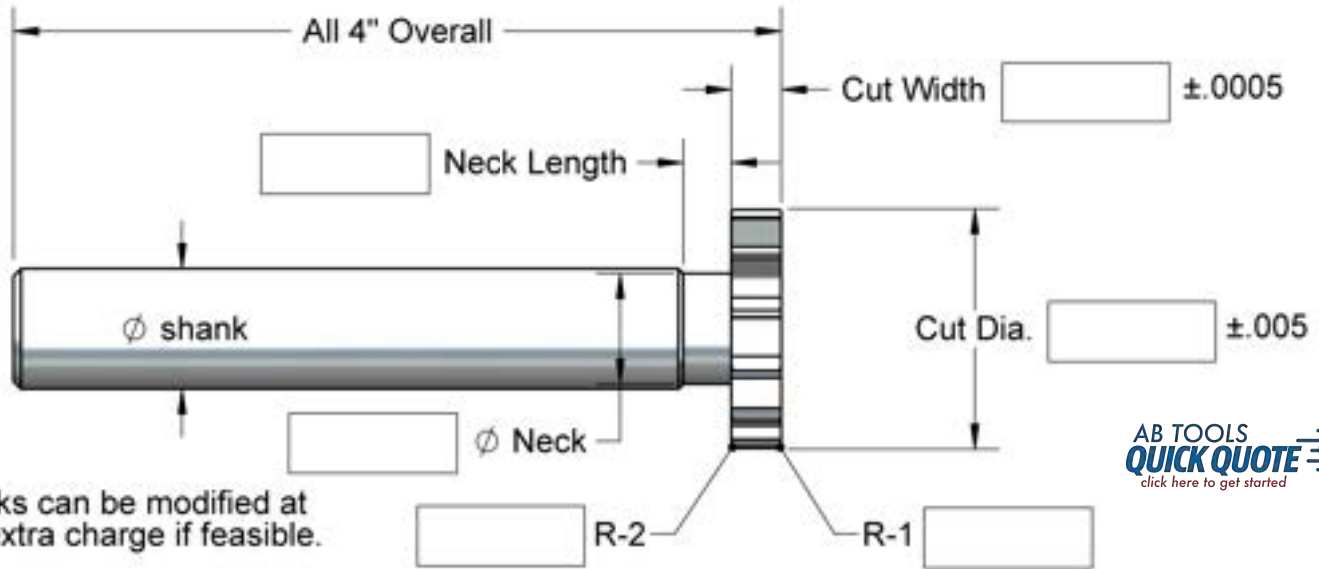

Necks can be modified at no extra charge if feasible.



One Chamfer **\$35.**  
Two Chamfers **\$50.**

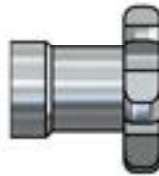

One Radius **\$40.**  
Two Radii **\$60.**  
Full Radius **\$60.**



Slot plus top Chamfers Upon Request

Number of flutes is your choice based on feasibility. We suggest coarse for non-ferrous, medium for titanium/stainless & maximum for cast iron and tough materials.

Suggested starting data:  
Ferrous 150 to 300 SFM; .001/.003 IPT  
Non-Ferrous 1K-3K SFM; .002/.006 IPT  
For thin or weak necked cutters, .0005 IPT

Cut Diameter	Max. # of Flutes	Shank Diameter	Basic Prices for .020 thru .135 Widths	Basic Prices for .136 thru .260 Widths	Basic Prices for .261 thru .374 Widths
.625	8	1/2"	<b>\$245.</b>	<b>\$260.</b>	<b>\$275.</b>
.750	10	1/2"	<b>\$260.</b>	<b>\$275.</b>	<b>\$300.</b>
1.00	12	1/2"	<b>\$275.</b>	<b>\$305.</b>	<b>\$330.</b>
1.125	12	5/8"	<b>\$305.</b>	<b>\$340.</b>	<b>\$365.</b>
1.25	14	5/8"	<b>\$325.</b>	<b>\$365.</b>	<b>\$385.</b>
1.375	14	3/4"	<b>\$370.</b>	<b>\$415.</b>	<b>\$435.</b>
1.50	16	3/4"	<b>\$415.</b>	<b>\$445.</b>	<b>\$480.</b>
1.75	18	3/4"	<b>\$470.</b>	<b>\$485.</b>	<b>\$525.</b>
2.00	20	3/4"	<b>\$500.</b>	<b>\$530.</b>	<b>\$560.</b>



A. B. TOOLS, INC.  
1051 Aviation Blvd.  
Lincoln, CA 95648-9312

Phone 916 408-2442  
FAX 916 993-3949

www.abtoolsinc.com  
E-Mail: mail@abtoolsinc.com

# Reduced Shank Solid Carbide Slotting Tools

**NEW !!!** from .140 to 1.510 diameters **NEW !!!**  
with your decimal width in 4-6 working days

Machining what part material, please? \_\_\_\_\_

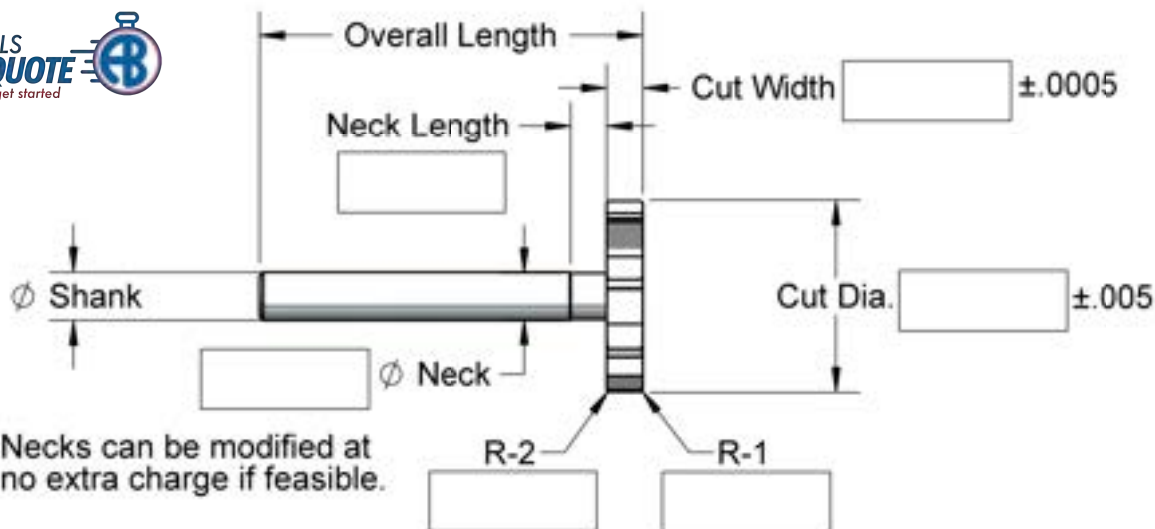

One Chamfer \$35.  
Two Chamfers \$50.

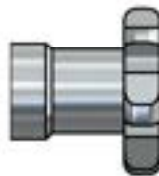

One Radius \$40.  
Two Radii \$60.  
Full Radius \$60.



Slot plus top Chamfers Upon Request

Number of flutes is your choice based on feasibility. We suggest coarse for non-ferrous, medium for titanium/stainless & maximum for cast iron and tough materials.

Suggested starting data:  
Ferrous 150 to 300 SFM; .001/.003 IPT  
Non-Ferrous 1K-3K SFM; .002/.006 IPT  
For thin or weak necked cutters, .0005 IPT

Shank & OAL	Cut Diameter	Width Range	Basic Prices
1/8" x 1-1/2"	.140 - .510	.020 - .188	<b>\$125.</b>
1/4" x 2"	.375 - 1.010	.020 - .250	<b>\$165.</b>
1/4" x 2"	.375 - 1.010	.251 - .440	<b>\$180.</b>
3/8" x 2"	.500 - 1.510	.030 - .375	<b>\$195.</b>
3/8" x 2-1/2"	.500 - 1.510	.376 - .440	<b>\$220.</b>



A. B. TOOLS, INC.  
1051 Aviation Blvd.  
Lincoln, CA 95648-9312

Phone 916 408-2442  
FAX 916 993-3949

www.abtoolsinc.com  
E-Mail: mail@abtoolsinc.com

# NEW !!! Picatinny/NATO Rail Cutters NEW !!!

AB TOOLS  
**QUICK QUOTE**  
click here to get started

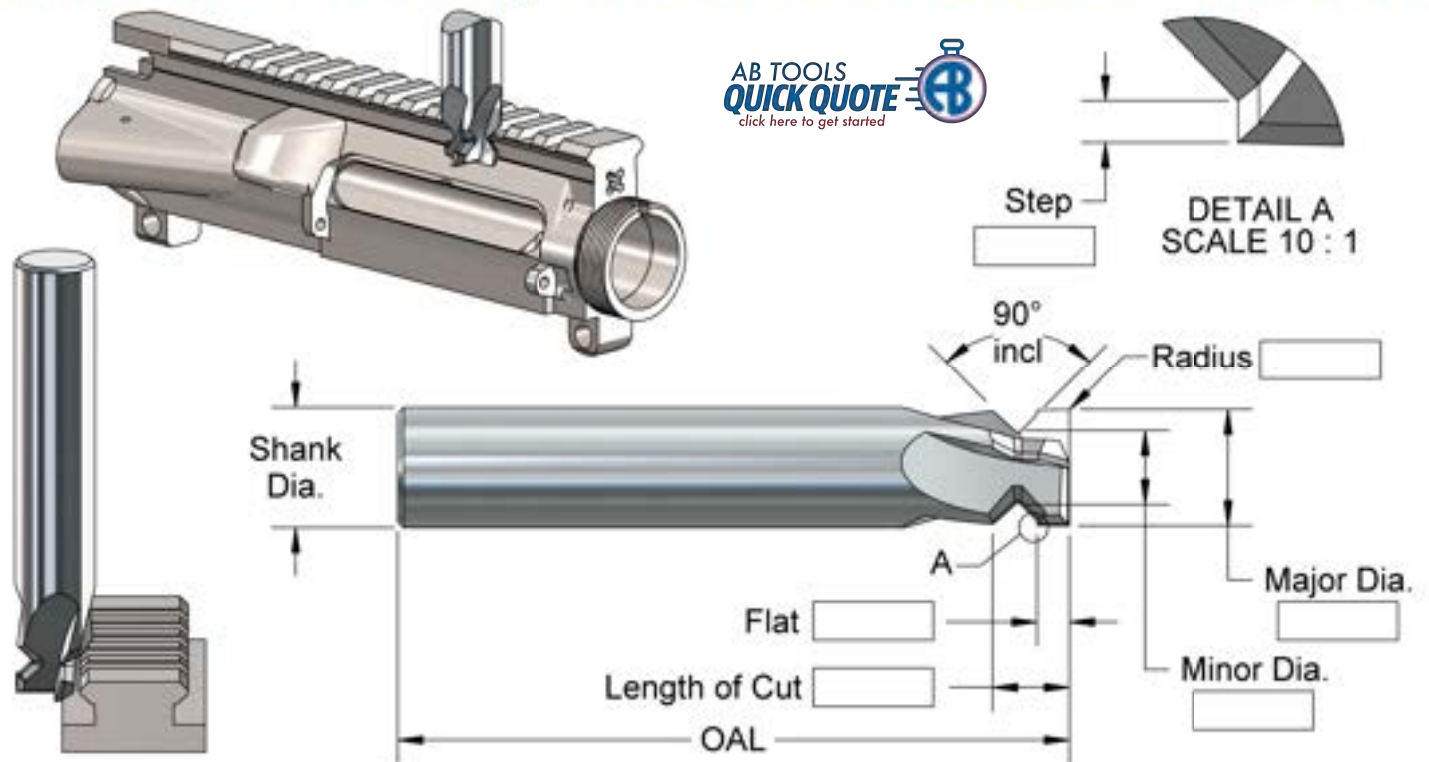

Number	Major Dia.	Minor Dia.	Length of Cut	Flat	Radius	Shank Dia.	OAL	No. of Flutes	Price
PT605-90H-3	.605	.385	.399	.167	None	5/8"	3.5	3	\$140.00
PT605-90H-4	.605	.385	.399	.167	None	5/8"	3.5	4	\$147.50
PT480-90H-2	.480	.260	.399	.167	None	1/2"	2.5	2	\$130.00
PT480-90H-3	.480	.260	.399	.167	None	1/2"	2.5	3	\$137.50
PTN625-90H-3*	.625	.405	.387	.143	.039	5/8"	3.5	3	\$150.00
PTN625-90H-4*	.625	.405	.387	.143	.039	5/8"	3.5	4	\$157.50
PTN500-90H-2*	.500	.280	.387	.143	.039	1/2"	2.5	2	\$135.00
PTN500-90H-3*	.500	.280	.387	.143	.039	1/2"	2.5	3	\$142.50

\* Cutter produces NATO rail

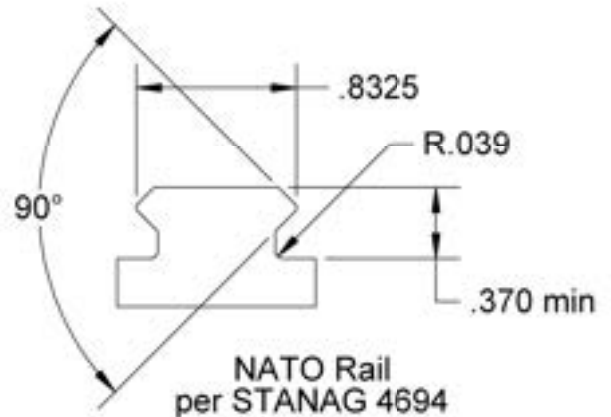
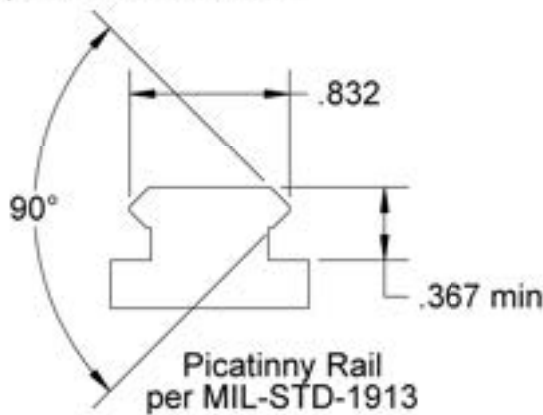

A. B. TOOLS, INC.  
1051 Aviation Blvd.  
Lincoln, CA 95648-9312

Phone 916 408-2442  
FAX 916 993-3949

www.abtoolsinc.com  
E-Mail: mail@abtoolsinc.com

# Solid Carbide Male Picatinny (Fixture) Cutter

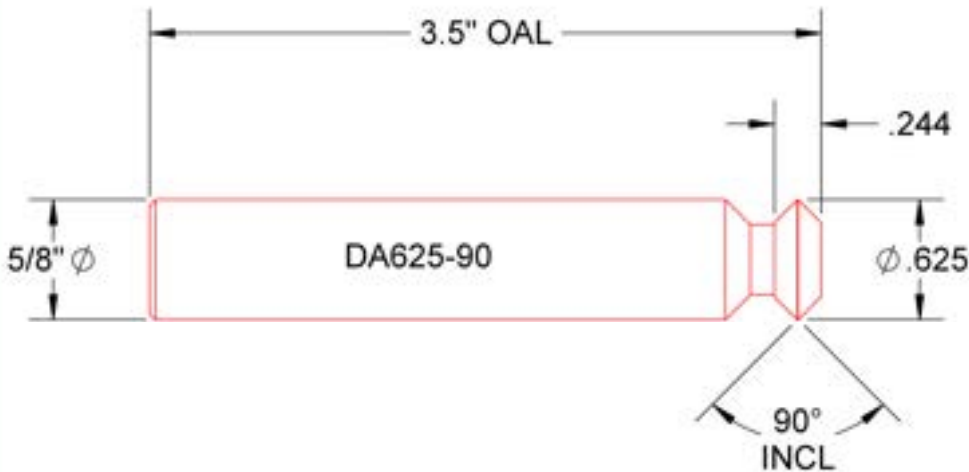

Number	Flutes	Price	
		No-Coat	AITIN
DA625-90-3	3	\$175.	\$197.
DA625-90-4	4	\$182.50	\$194.50

## Special Male Picatinny (Fixture) Cutters in 4-6 Working Days

Machining what part material, please? \_\_\_\_\_

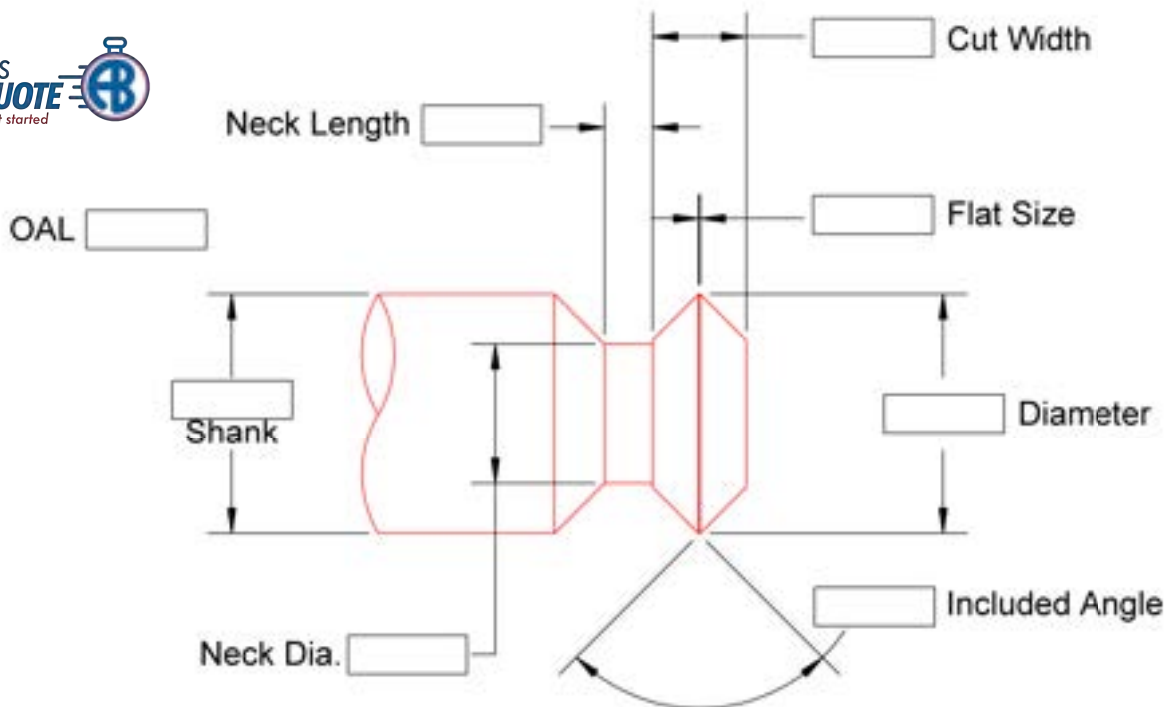

A. B. TOOLS, INC.  
1051 Aviation Blvd.  
Lincoln, CA 95648-9312

Phone 916 408-2442  
FAX 916 993-3949

www.abtoolsinc.com  
E-Mail: mail@abtoolsinc.com

# Solid Carbide Slot & Chamfer Picatinny Rail End Mill

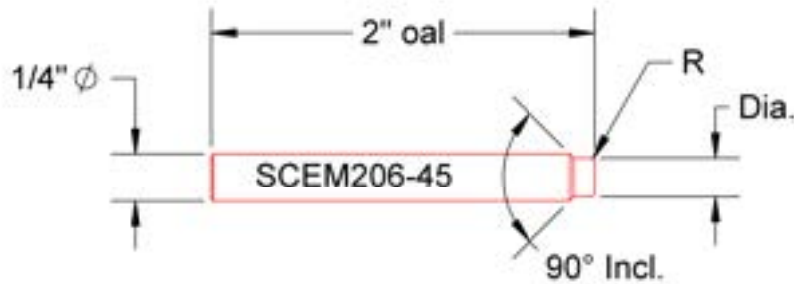

Number	Dia.	Radius	Price			AlTiN add
			3 flutes	4 flutes	5 flutes	
SCSEM206-45	.206	None	\$60.	\$70.	\$81.	\$4.
SCSEM206-45-10R	.206	.010	\$70.	\$81.	\$91.	\$4.
SCSEM206-45-20R	.206	.020	\$70.	\$81.	\$91.	\$4.
SCSEM210-45	.210	None	\$60.	\$70.	\$81.	\$4.
SCSEM210-45-10R	.210	.010	\$70.	\$81.	\$91.	\$4.
SCSEM210-45-20R	.210	.020	\$70.	\$81.	\$91.	\$4.

## Special Slot & Chamfer End Mills in 4-6 Working Days

Machining what part material, please? \_\_\_\_\_

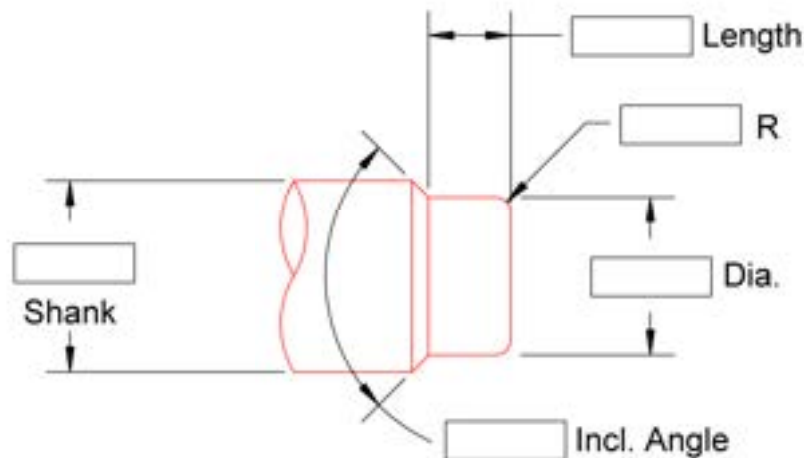

A. B. TOOLS, INC.  
1051 Aviation Blvd.  
Lincoln, CA 95648-9312

Phone 916 408-2442  
FAX 916 993-3949

www.abtoolsinc.com  
E-Mail: mail@abtoolsinc.com

# Solid Carbide Keymod Cutter

(3) flutes

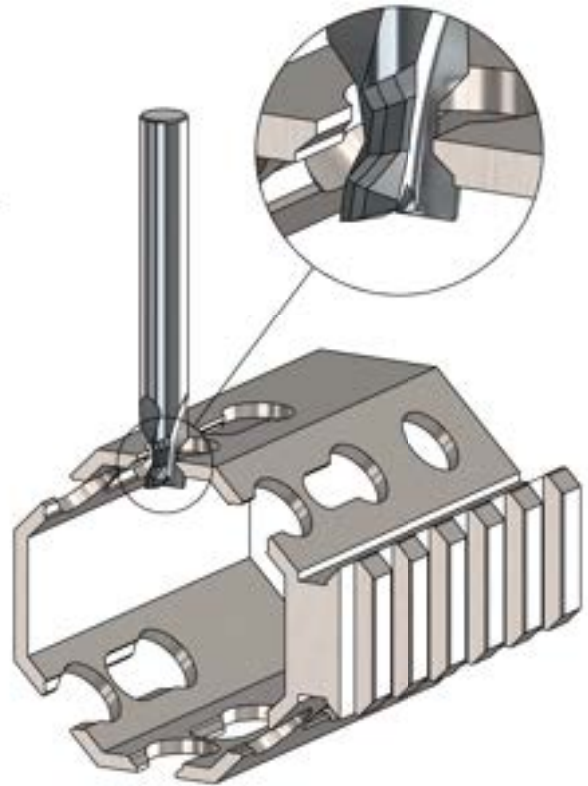

Number	Price	
	No-Coat	AlTiN
KM230-100	\$90.	\$94.

**Special Keymod Cutters in 4-6 Working Days**

Machining what part material, please? \_\_\_\_\_

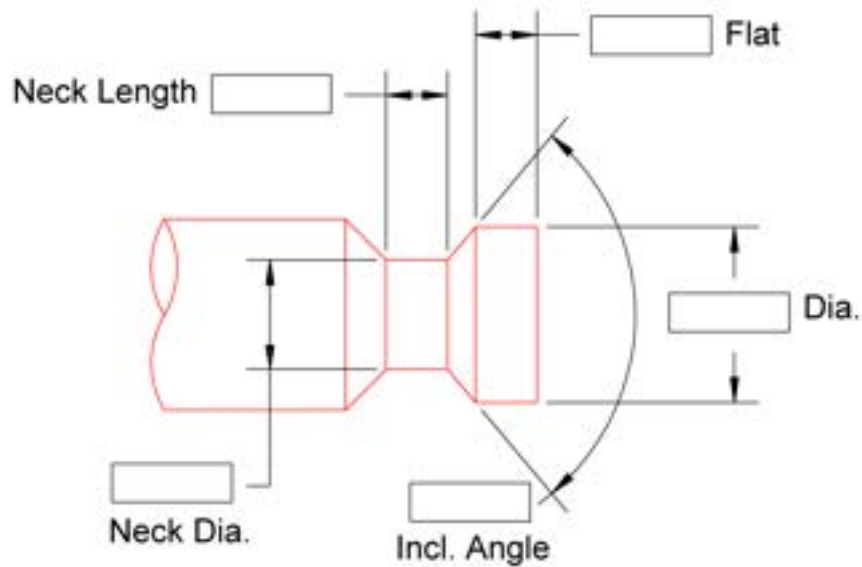

A. B. TOOLS, INC.  
1051 Aviation Blvd.  
Lincoln, CA 95648-9312

Phone 916 408-2442  
FAX 916 993-3949

www.abtoolsinc.com  
E-Mail: mail@abtoolsinc.com



# Charging Handle Slot Cutter

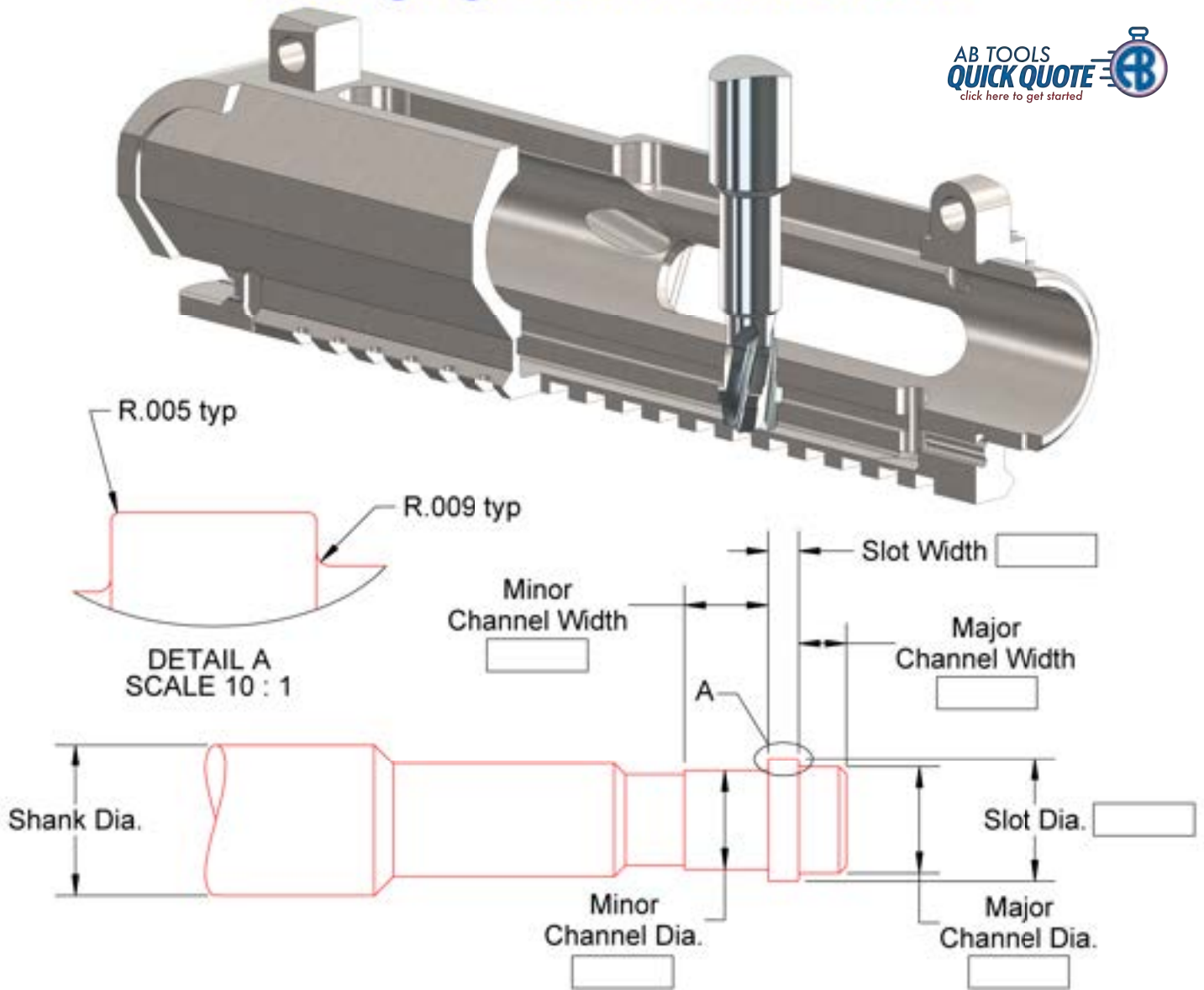

## Special Charging Handle Slot Cutters in 4-6 working days

Machining what part material, please? \_\_\_\_\_

Number	Slot Dia.	Slot Width	Helix	Shank Dia. & OAL	No. of Flutes	Price	
						No-Coat	AlTiN
CHSC-R15	.486	.127	15°	5/8 X 5	3	\$240.	\$255.
CHSC-R30	.486	.127	30°	5/8 X 5	3	\$240.	\$255.
CHSC-F15	.506	.127	15°	5/8 X 5	4	\$240.	\$255.
CHSC-F30	.506	.127	30°	5/8 X 5	4	\$240.	\$255.



A. B. TOOLS, INC.  
1051 Aviation Blvd.  
Lincoln, CA 95648-9312

Phone 916 408-2442  
FAX 916 993-3949

www.abtoolsinc.com  
E-Mail: mail@abtoolsinc.com

# Solid Carbide Dovetail Cutters for O-Ring Grooves

NUMBER	O-RING SIZE	NECK Ø TSC	NECK Ø OVER R	SLOT DEPTH	TOP RAD.	BOTTOM RAD.	MAJOR Ø	PRICE	AITIN
DT1/16 DT1/16-5	.070	.057 .052	.0624 .0574	.051	.005	.015	.0862 .0812	\$68.	\$72.
DT1/16-054	.070	.059	.064	.054	.005	.016	.090	\$68.	\$72.
DT3/32 DT3/32-8	.103	.085 .077	.0958 .0878	.082	.010	.015	.1418 .1338	\$68.	\$72.
DT1/8 DT1/8-10	.139	.115 .105	.1258 .1158	.112	.010	.031	.1812 .1712	\$75.	\$79.
DT3/16 DT3/16-12	.210	.173 .161	.1892 .1772	.172	.015	.031	.2927 .2807	\$85.	\$92.
DT1/4 DT1/4-15	.275	.233 .218	.2492 .2342	.232	.015	.062	.3726 .3576	\$100.	\$107.
DT3/8 DT3/8-15	.375	.317 .302	.3386 .3236	.317	.020	.094	.4978 .4828	\$130.	\$139.

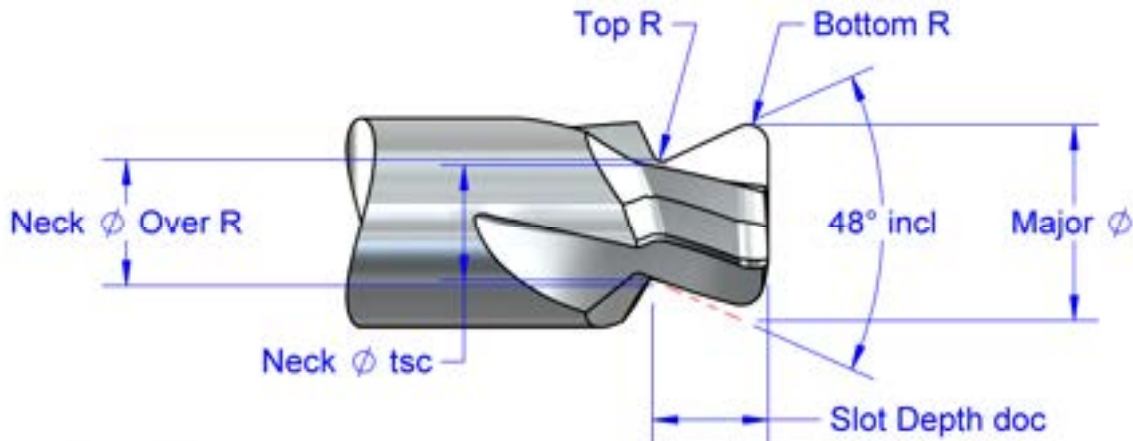

Reference Chart

NUMBER	NO. OF FLUTES	SHANK Ø	OAL
DT1/16 DT1/16-5	1	3/16	2
DT1/16-054	2	3/16	2
DT3/32 DT3/32-8	2	3/16	2
DT1/8 DT1/8-10	2	1/4	2
DT3/16 DT3/16-12	3	5/16	2.5
DT1/4 DT1/4-15	3	3/8	2.5
DT3/8 DT3/8-15	4	1/2	2.5

**Specials in 4-6  
Working Days  
(See Page 18)**



A. B. TOOLS, INC.  
1051 Aviation Blvd.  
Lincoln, CA 95648-9312

Phone 916 408-2442  
FAX 916 993-3949

www.abtoolsinc.com  
E-Mail: mail@abtoolsinc.com

# Solid Carbide Dovetail for O-Ring Grooves (Metric)

NUMBER	O-RING SIZE	NECK Ø TSC	NECK Ø OVER R	SLOT DEPTH	TOP RAD.	BOTTOM RAD.	MAJOR Ø	PRICE	AITiN
DT3MM	3MM	.096	.102	.094	.010	.016	.162	\$68.	\$72.
DT3.5MM	3.5MM	.110	.121	.110	.010	.031	.1745	\$68.	\$72.
DT4MM	4MM	.122	.133	.126	.010	.031	.201	\$72.	\$76.
DT4.5MM	4.5MM	.138	.149	.144	.010	.031	.232	\$72.	\$76.
DT5MM	5MM	.152	.162	.163	.010	.031	.264	\$85.	\$92.
DT5.5MM	5.5MM	.165	.183	.181	.016	.031	.293	\$85.	\$92.
DT6MM	6MM	.179	.196	.199	.016	.031	.323	\$100.	\$107.
DT6.5MM	6.5MM	.193	.210	.2165	.016	.031	.352	\$100.	\$107.
DT7MM	7MM	.207	.224	.234	.016	.059	.352	\$100.	\$107.
DT7.5MM	7.5MM	.2205	.238	.252	.016	.059	.381	\$130.	\$139.
DT8MM	8MM	.236	.258	.270	.020	.059	.413	\$130.	\$139.
DT8.5MM	8.5MM	.250	.272	.289	.020	.059	.444	\$130.	\$139.
DT9MM	9MM	.264	.285	.307	.020	.059	.473	\$130.	\$139.
DT9.5MM	9.5MM	.278	.299	.323	.020	.059	.501	\$130.	\$139.
DT10MM	10MM	.291	.313	.3425	.020	.059	.533	\$165.	\$178.

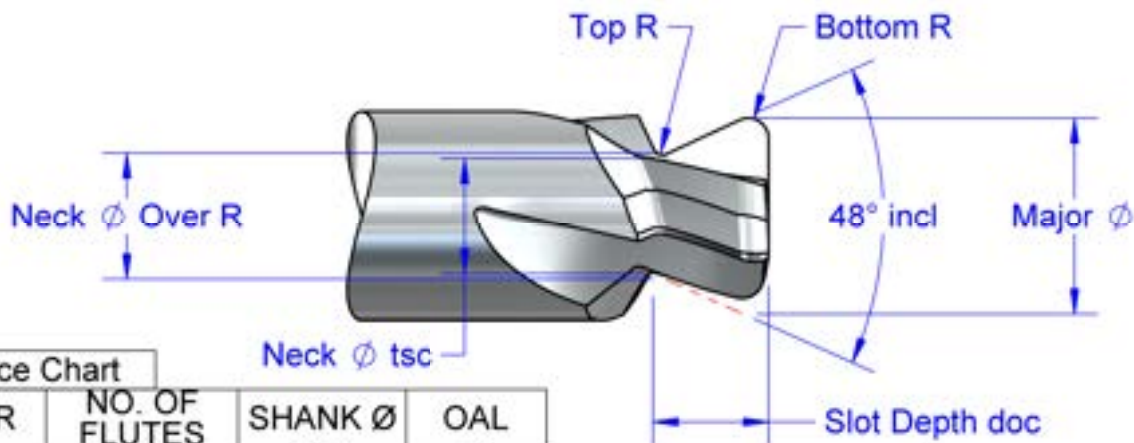

NUMBER	NO. OF FLUTES	SHANK Ø	OAL
DT3MM	2	3/16	2
DT3.5MM	2	3/16	2
DT4MM	2	1/4	2
DT4.5MM	2	1/4	2
DT5MM	3	5/16	2.5
DT5.5MM	3	5/16	2.5
DT6MM	3	3/8	2.5
DT6.5MM	3	3/8	2.5
DT7MM	3	3/8	2.5
DT7.5MM	3	1/2	2.5
DT8MM	3	1/2	2.5
DT8.5MM	3	1/2	2.5
DT9MM	3	1/2	2.5
DT9.5MM	3	1/2	2.5
DT10MM	3	5/8	3.5

**Specials in 4-6  
Working Days  
(See Page 18)**



A. B. TOOLS, INC.  
1051 Aviation Blvd.  
Lincoln, CA 95648-9312

Phone 916 408-2442  
FAX 916 993-3949

www.abtoolsinc.com  
E-Mail: mail@abtoolsinc.com

# Solid Carbide Dovetail Cutters for O-Ring Grooves WITHOUT Drop Hole Provision

NUMBER	O-RING SIZE	PART Ø TSC	NECK Ø OVER R	SLOT DEPTH	TOP RAD.	BOTTOM RAD.	NO. OF FLUTES	PRICE	AITiN
DTNDH1/16	.070	.057	.036	.051	.005	.015	1	\$68.	\$72.
DTNDH3/32	.103	.085	.048	.082	.010	.015	1	\$68.	\$72.
DTNDH1/8	.139	.115	.0685	.112	.010	.031	2	\$75.	\$79.
DTNDH3/16	.210	.173	.0835	.172	.015	.031	2	\$85.	\$90.
DTNDH1/4	.275	.233	.1235	.232	.015	.062	2	\$100.	\$107.
DTNDH3/8	.375	.317	.178	.317	.020	.094	3	\$130.	\$137.

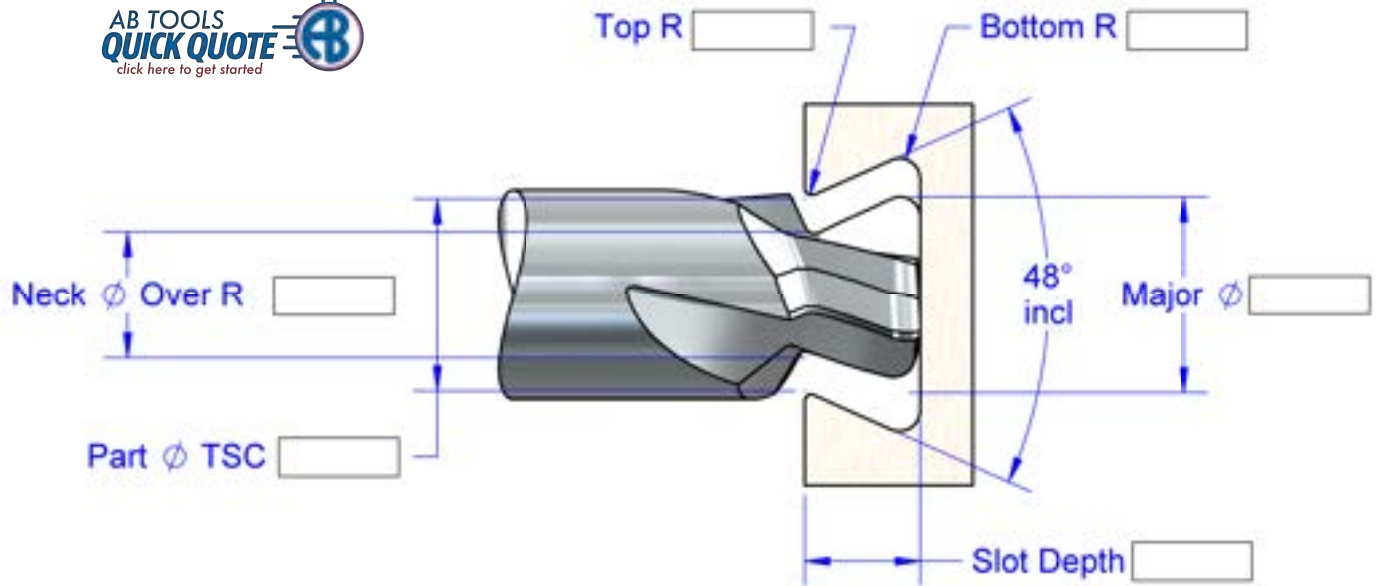

Reference Chart

NUMBER	MAJOR Ø	SHANK Ø	OAL
DTNDH1/16	.060	3/16	2
DTNDH3/32	.094	3/16	2
DTNDH1/8	.124	3/16	2
DTNDH3/16	.187	1/4	2
DTNDH1/4	.247	5/16	2.5
DTNDH3/8	.337	3/8	2.5

**Specials in 4-6 Working Days**



A. B. TOOLS, INC.  
1051 Aviation Blvd.  
Lincoln, CA 95648-9312

Phone 916 408-2442  
FAX 916 993-3949

www.abtoolsinc.com  
E-Mail: mail@abtoolsinc.com

# Solid Carbide Dovetail Cutters for Half Dovetail O-Ring Grooves

NUMBER	O-RING SIZE	PART Ø TSC	NECK Ø OVER R	SLOT DEPTH	TOP RAD.	BOTTOM RAD.	NO. OF FLUTES	PRICE	AITIN
HDG1/16	.070	.065	.0545	.054	.005	.015	2	\$68.	\$72.
HDG3/32	.103	.096	.0775	.084	.010	.015	2	\$68.	\$72.
HDG1/8	.139	.126	.103	.114	.010	.031	2	\$75.	\$79.
HDG3/16	.210	.1915	.146	.1745	.015	.031	2	\$85.	\$92.
HDG1/4	.275	.256	.2005	.236	.015	.062	3	\$100.	\$107.
HDG3/8	.375	.354	.283	.321	.020	.093	4	\$130.	\$139.

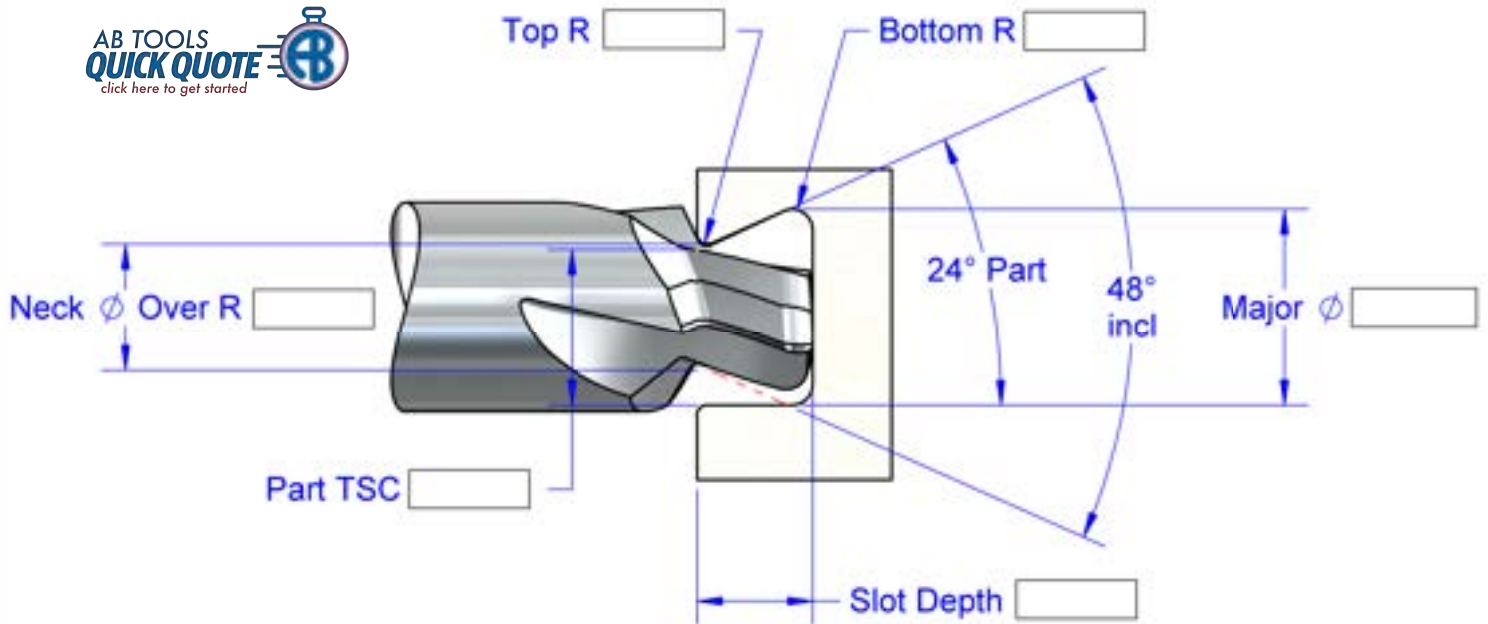

## Reference Chart

NUMBER	MAJOR Ø	SHANK Ø	OAL
HDG1/16	.081	3/16	2
HDG3/32	.125	3/16	2
HDG1/8	.160	3/16	2
HDG3/16	.253	5/16	2.5
HDG1/4	.328	3/8	2.5
HDG3/8	.447	1/2	2.5

**Specials in 4-6 Working Days**



A. B. TOOLS, INC.  
1051 Aviation Blvd.  
Lincoln, CA 95648-9312

Phone 916 408-2442  
FAX 916 993-3949

www.abtoolsinc.com  
E-Mail: mail@abtoolsinc.com

# Solid Carbide Dovetail Cutters for O-Ring Grooves

## Specials in 4-6 working days

Machining what part material, please? \_\_\_\_\_

Number of flutes is based on part material and Neck  $\phi$ .

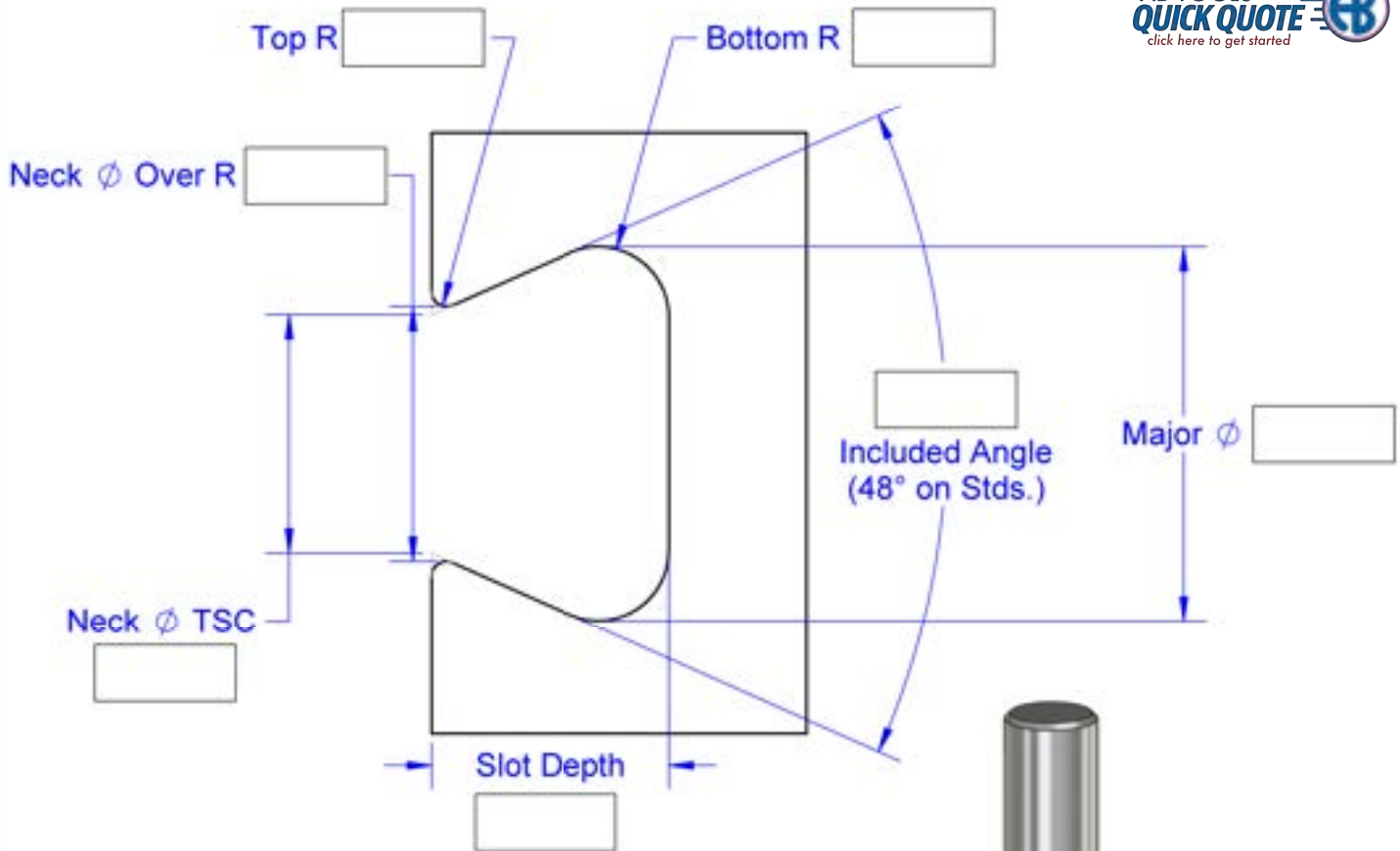

Shank  $\phi$  and overall length are based on cutter Major  $\phi$ . Or per request if feasible.

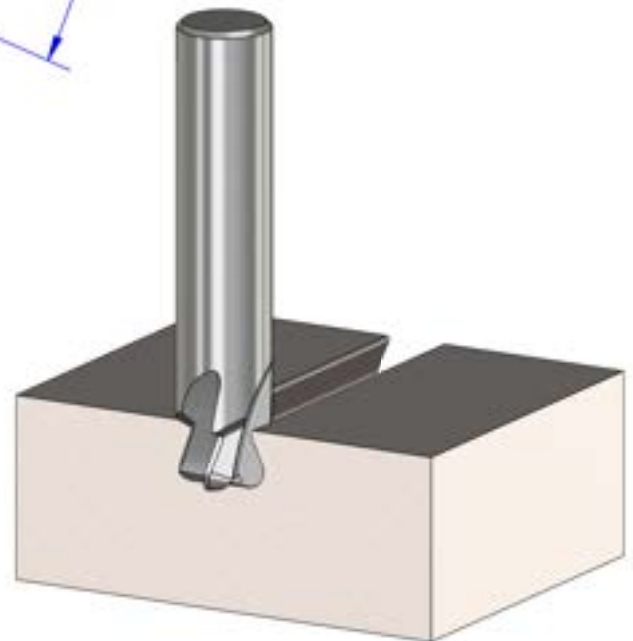

Basic Prices		
Major $\phi$	1 tool	2 tools
Up to .250	<b>\$160.</b>	<b>\$135. ea</b>
.251 thru .375	<b>\$195.</b>	<b>\$150. ea</b>
.376 thru .500	<b>\$235.</b>	<b>\$165. ea</b>
.501 thru .625	<b>\$325.</b>	<b>\$240. ea</b>
.626 thru .750	<b>\$360.</b>	<b>\$265. ea</b>



A. B. TOOLS, INC.  
1051 Aviation Blvd.  
Lincoln, CA 95648-9312

Phone 916 408-2442  
FAX 916 993-3949

www.abtoolsinc.com  
E-Mail: mail@abtoolsinc.com

# Solid Carbide O-Ring Dovetails for Lathes



Single flute carbide O-Ring form tools for lathe applications that match Parker-Hannifin standards

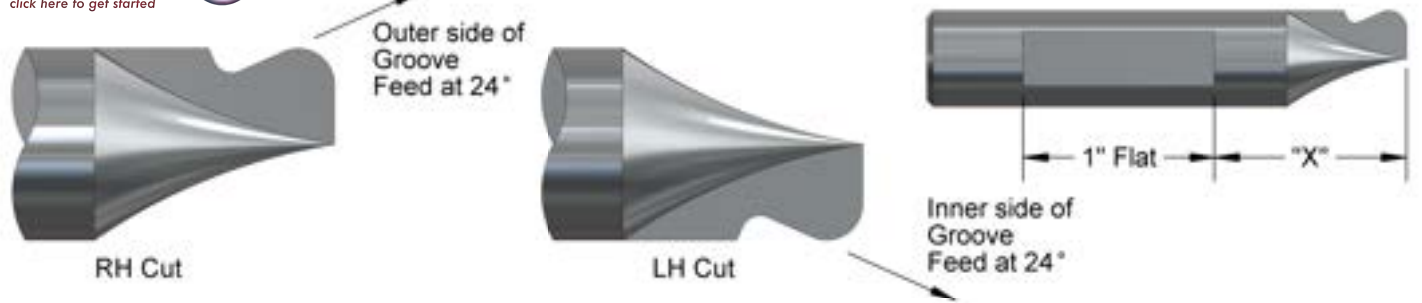

NUMBER		O'RING DIA.	*NECK DIA.	SLOT DEPTH	TOP RAD.	BOTT. RAD.	X	SHANK & OAL	PRICES	
RH Cut	LH Cut								No Coat	AlTiN
DTL1/16-R	DTL1/16-L	.070	.057	.051	.005	.015	1/2"	3/16 X 2	\$78.	\$82.
DTL1/16-054-R	DTL1/16-054-L	.070	.059	.054	.005	.016	1/2"	3/16 X 2	\$78.	\$82.
DTL3/32-R	DTL3/32-L	.103	.085	.082	.010	.015	1/2"	3/16 X 2	\$78.	\$82.
DTL1/8-R	DTL1/8-L	.139	.115	.112	.010	.031	5/8"	1/4 X 2	\$85.	\$89.
DTL3/16-R	DTL3/16-L	.210	.173	.172	.015	.031	3/4"	5/16 X 2.5	\$95.	\$102.
DTL1/4-R	DTL1/4-L	.275	.233	.232	.015	.062	7/8"	3/8 X 2.5	\$110.	\$117.
DTL3/8-R	DTL3/8-L	.375	.317	.317	.020	.094	1"	1/2 X 2.5	\$155.	\$164.

## Specials in 4-6 working days

Machining what part material, please? \_\_\_\_\_

Low Carbon Steel: 500 SFM, .0005-.0010 IPR  
 Aluminum: 6000 SFM, .0005-.0010 IPR  
 304 SS: 225 SFM, .0005-.0010 IPR

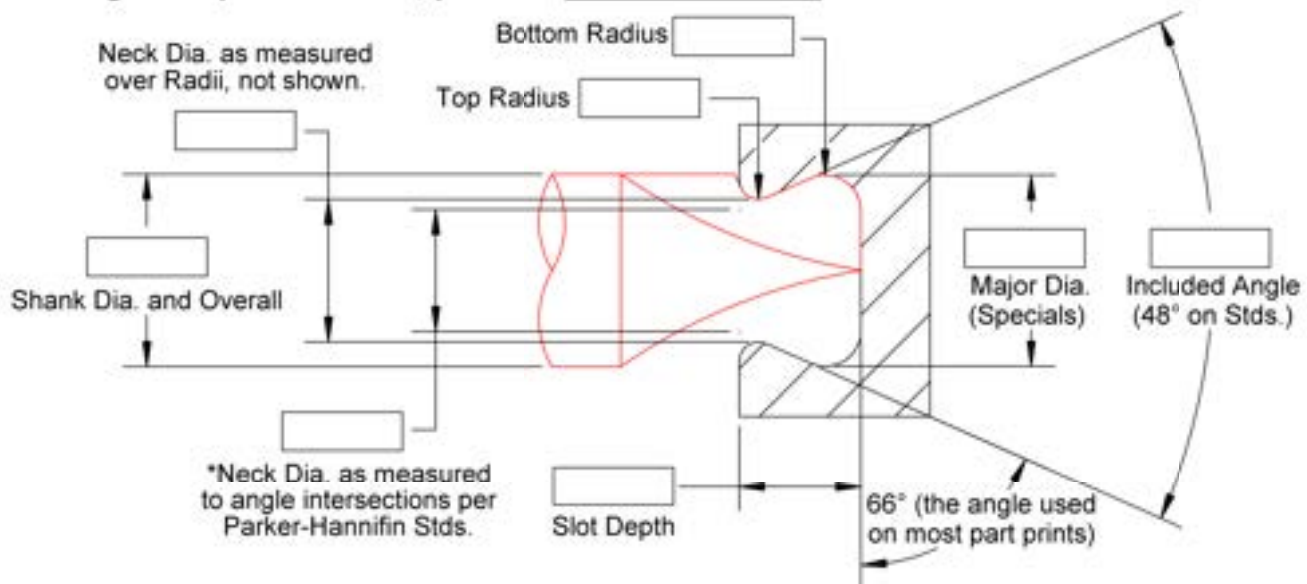

Special Carbide Cutters for O-Ring Grooves	To 1/4 Major Diameter	1 at \$175. and 2 at \$150. each
	.251 thru .375 Major Dia.	1 at \$210. and 2 at \$165. each
	.376 thru .500 Major Dia.	1 at \$250. and 2 at \$180. each



A. B. TOOLS, INC.  
 1051 Aviation Blvd.  
 Lincoln, CA 95648-9312

Phone 916 408-2442  
 FAX 916 993-3949

www.abtoolsinc.com  
 E-Mail: mail@abtoolsinc.com

# Solid Carbide DSP Cutters for protective cable grooves

Number	"G"	"N"	"F"	"V"	Shank Ø	OAL	Flutes	Price
DSP-02	.047	.023	.0125	.026	3/16	2	2	\$70.
DSP-03	.064	.036	.021	.034	3/16	2	2	\$70.
DSP-04B	.095	.045	.022	.049	3/16	2	2	\$75.
DSP-070	.095	.053	.0325	.054	3/16	2	2	\$75.
DSP-05B	.110	.059	.035	.062	3/16	2	2	\$75.
DSP-06	.126	.071	.0455	.075	3/16	2	2	\$80.
DSP-103	.142	.077	.048	.084	3/16	2	2	\$80.
DSP-07B	.157	.079	.0485	.094	3/16	2	2	\$80.
DSP-08	.172	.096	.060	.100	3/16	2	2	\$80.
DSP-139	.188	.113	.0715	.105	1/4	2	2	\$90.
DSP-09	.188	.105	.0705	.119	1/4	2	2	\$90.
DSP-11	.235	.129	.0835	.144	1/4	2	2	\$90.
DSP-12	.251	.147	.093	.144	3/8	2.5	2	\$100.
DSP-16	.344	.185	.128	.229	3/8	2.5	2	\$105.
DSP-20	.407	.233	.164	.269	1/2	2.5	3	\$120.
DSP-24	.501	.280	.196	.333	1/2	2.5	3	\$175.
DSP-32	.657	.377	.267	.437	3/4	3	4	\$240.

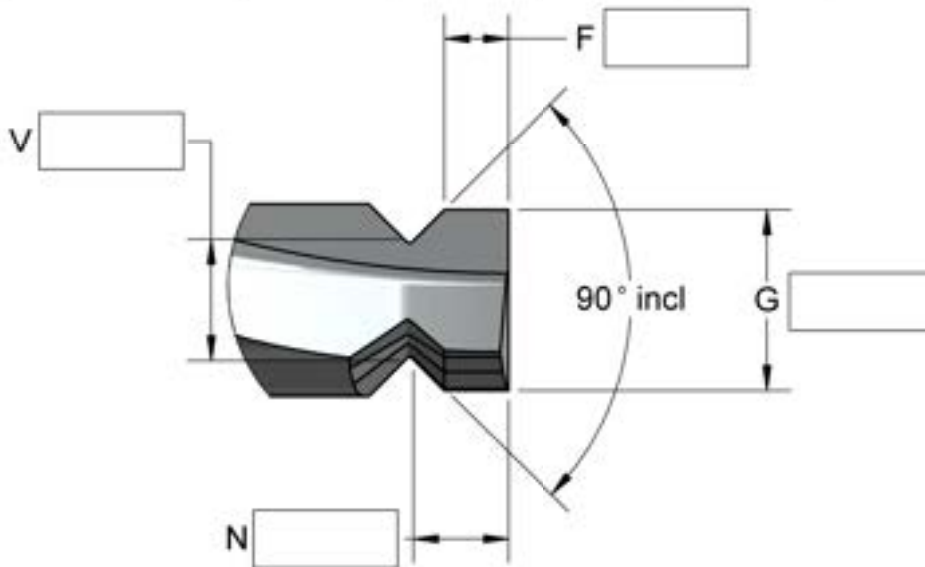

**Specials in 4-6  
Working Days**

## Multi Seal Solid Carbide DMSP Cutter

Number	"G"	"N"	"F"	"V"	Shank Ø	OAL	Flutes	Price
DMSP-04	.187	.051	.016	.117	3/16	2	2	\$80.
DMSP-06	.250	.074	.028	.159	3/8	2.5	2	\$90.
DMSP-08	.313	.086	.044	.229	3/8	2.5	3	\$100.
DMSP-12	.500	.145	.063	.336	1/2	2.5	3	\$175.
DMSP-16	.625	.192	.106	.454	5/8	3.5	4	\$205.



A. B. TOOLS, INC.  
1051 Aviation Blvd.  
Lincoln, CA 95648-9312

Phone 916 408-2442  
FAX 916 993-3949

www.abtoolsinc.com  
E-Mail: mail@abtoolsinc.com



# Solid Carbide Dovetail Cutters

1/8" Major Ø x 1.5" OAL. With 1/8" Neck Length. 3 Flutes.

Number	A°	Cut Lngth	Neck Ø	Flat	Price	AlTiN
DS1/8-10	10	.188	.090	.001	\$60.	\$65.
DS1/8-20	20	.125	.080	.001	\$60.	\$65.
DS1/8-30	30	.090	.075	.001	\$60.	\$65.
DS1/8-40	40	.080	.065	.001	\$60.	\$65.
DS1/8-45	45	.070	.065	.001	\$60.	\$65.
DS1/8-50	50	.065	.065	.002	\$60.	\$65.
DS1/8-60	60	.050	.065	.002	\$60.	\$65.
DS1/8-70	70	.040	.065	.002	\$60.	\$65.
DS1/8-80	80	.035	.065	.002	\$60.	\$65.
DS1/8-90	90	.030	.065	.002	\$60.	\$65.
DS1/8-100	100	.025	.065	.003	\$60.	\$65.
DS1/8-120	120	.020	.065	.003	\$60.	\$65.

3/16" Major Ø x 2" OAL. With 1/8" Neck Length. 3 Flutes.

Number	A°	Cut Lngth	Neck Ø	Flat	Price	AlTiN
DS3/16-10	10	.270	.140	.001	\$62.50	\$66.
DS3/16-20	20	.210	.110	.001	\$62.50	\$66.
DS3/16-30	30	.160	.100	.001	\$62.50	\$66.
DS3/16-40	40	.130	.090	.001	\$62.50	\$66.
DS3/16-45	45	.115	.090	.001	\$62.50	\$66.
DS3/16-50	50	.100	.090	.002	\$62.50	\$66.
DS3/16-60	60	.080	.090	.002	\$62.50	\$66.
DS3/16-70	70	.070	.090	.002	\$62.50	\$66.
DS3/16-80	80	.055	.090	.002	\$62.50	\$66.
DS3/16-90	90	.050	.090	.002	\$62.50	\$66.
DS3/16-100	100	.040	.090	.003	\$62.50	\$66.
DS3/16-120	120	.030	.090	.003	\$62.50	\$66.

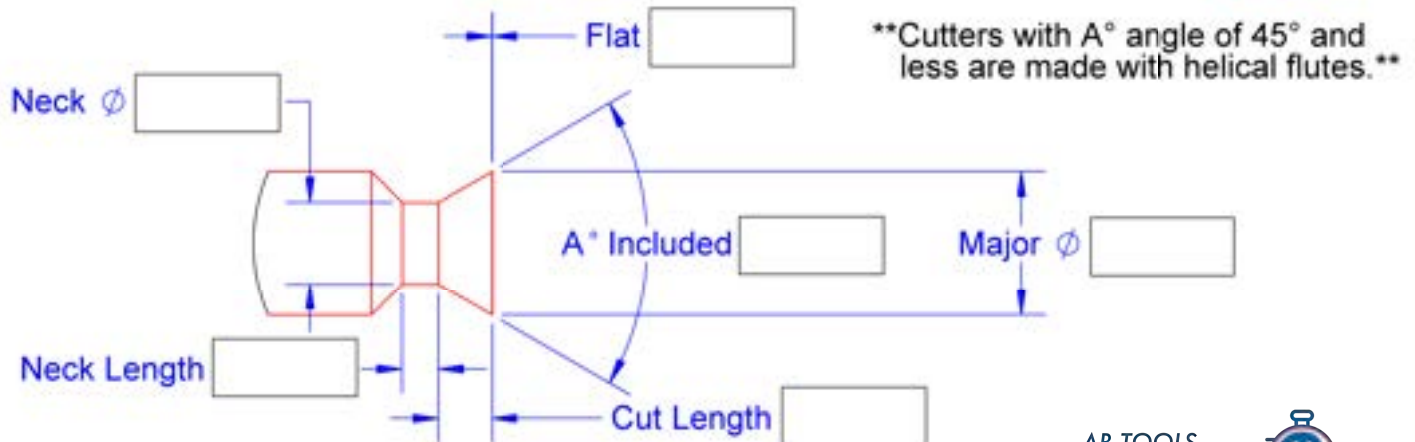

1/4" Major Ø x 2" OAL. With 1/8" Neck Length. 3 Flutes.

Number	A°	Cut Lngth	Neck Ø	Flat	Price	AlTiN
DS1/4-10	10	.320	.160	.001	\$65.	\$70.
DS1/4-20	20	.300	.130	.001	\$65.	\$70.
DS1/4-30	30	.250	.115	.001	\$65.	\$70.
DS1/4-32	32	.125	.155	N/A	\$65.	\$70.
DS1/4-40	40	.190	.110	.001	\$65.	\$70.
DS1/4-45	45	.165	.110	.001	\$65.	\$70.
DS1/4-50	50	.150	.110	.002	\$65.	\$70.
DS1/4-60	60	.120	.110	.002	\$65.	\$70.
DS1/4-70	70	.100	.110	.002	\$65.	\$70.
DS1/4-80	80	.085	.110	.002	\$65.	\$70.
DS1/4-90	90	.070	.110	.002	\$65.	\$70.
DS1/4-100	100	.060	.110	.003	\$65.	\$70.
DS1/4-120	120	.045	.110	.003	\$65.	\$70.



**Specials in 4-6 Working Days**



A. B. TOOLS, INC.  
1051 Aviation Blvd.  
Lincoln, CA 95648-9312

Phone 916 408-2442  
FAX 916 993-3949

www.abtoolsinc.com  
E-Mail: mail@abtoolsinc.com

# Solid Carbide Dovetail Cutters

3/8" Major Ø x 2.5" OAL. With 3/16" Neck Length. 3 Flutes.

Number	A°	Cut Lngth	Neck Ø	Flat	Price	AlTiN
DS3/8-10	10	.370	.260	.001	\$82.50	\$89.
DS3/8-20	20	.370	.230	.001	\$82.50	\$89.
DS3/8-30	30	.370	.170	.001	\$82.50	\$89.
DS3/8-40	40	.260	.170	.001	\$82.50	\$89.
DS3/8-45	45	.235	.170	.001	\$82.50	\$89.
DS3/8-50	50	.210	.170	.002	\$82.50	\$89.
DS3/8-60	60	.180	.170	.002	\$82.50	\$89.
DS3/8-70	70	.145	.170	.002	\$82.50	\$89.
DS3/8-80	80	.130	.160	.002	\$82.50	\$89.
DS3/8-90	90	.110	.160	.002	\$82.50	\$89.
DS3/8-100	100	.090	.160	.003	\$82.50	\$89.
DS3/8-120	120	.060	.160	.003	\$82.50	\$89.

1/2" Major Ø x 2.5" OAL. With 3/16" Neck Length. 3 Flutes.

Number	A°	Cut Lngth	Neck Ø	Flat	Price	AlTiN
DS1/2-10	10	.500	.360	.001	\$95.	\$104.
DS1/2-20	20	.400	.300	.001	\$95.	\$104.
DS1/2-30	30	.320	.200	.001	\$95.	\$104.
DS1/2-40	40	.320	.180	.001	\$95.	\$104.
DS1/2-45	45	.320	.180	.001	\$95.	\$104.
DS1/2-50	50	.320	.180	.002	\$95.	\$104.
DS1/2-60	60	.250	.180	.002	\$95.	\$104.
DS1/2-70	70	.210	.180	.002	\$95.	\$104.
DS1/2-80	80	.180	.180	.002	\$95.	\$104.
DS1/2-90	90	.140	.180	.002	\$95.	\$104.
DS1/2-100	100	.120	.180	.003	\$95.	\$104.
DS1/2-120	120	.090	.180	.003	\$95.	\$104.

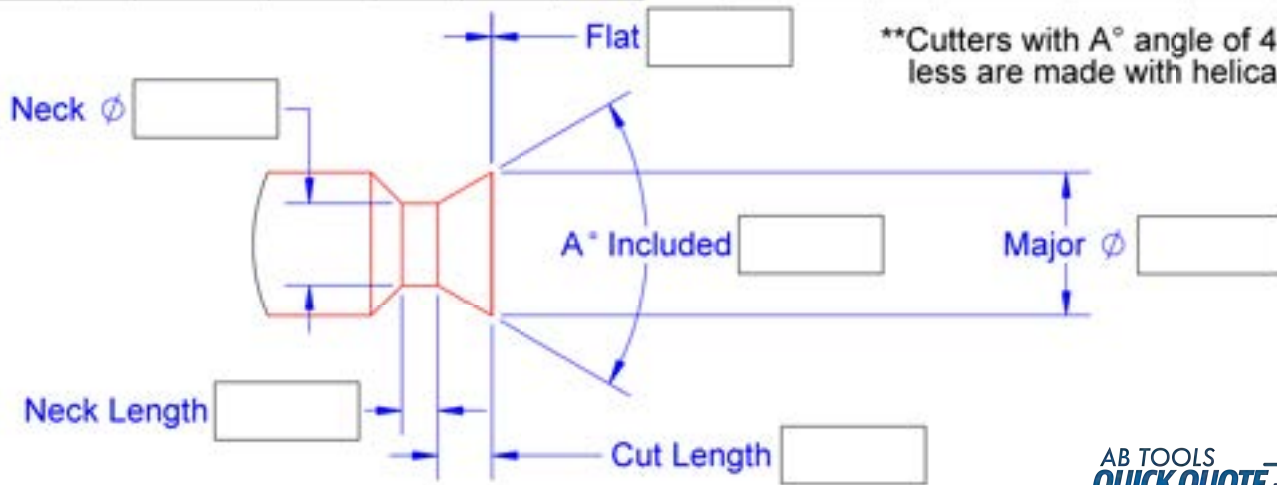

**\*\*Cutters with A° angle of 45° and less are made with helical flutes.\*\***

5/8" Major Ø x 3" OAL. With 3/16" Neck Length. 4 Flutes.

Number	A°	Cut Lngth	Neck Ø	Flat	Price	AlTiN
DS5/8-10	10	.600	.500	.001	\$135.	\$144.
DS5/8-20	20	.500	.440	.001	\$135.	\$144.
DS5/8-30	30	.450	.360	.001	\$135.	\$144.
DS5/8-40	40	.400	.330	.001	\$135.	\$144.
DS5/8-45	45	.350	.330	.001	\$135.	\$144.
DS5/8-50	50	.310	.330	.002	\$135.	\$144.
DS5/8-60	60	.250	.330	.002	\$135.	\$144.
DS5/8-70	70	.210	.330	.002	\$135.	\$144.
DS5/8-80	80	.185	.310	.002	\$135.	\$144.
DS5/8-90	90	.150	.310	.002	\$135.	\$144.
DS5/8-100	100	.130	.310	.003	\$135.	\$144.
DS5/8-120	120	.090	.310	.003	\$135.	\$144.



click here to get started

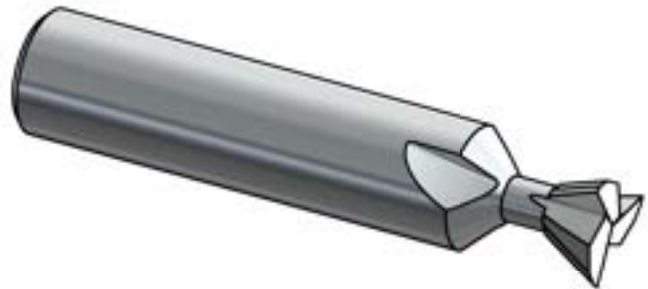

**Specials in 4-6 Working Days**



A. B. TOOLS, INC.  
1051 Aviation Blvd.  
Lincoln, CA 95648-9312

Phone 916 408-2442  
FAX 916 993-3949

www.abtoolsinc.com  
E-Mail: mail@abtoolsinc.com

# Solid Carbide Corner Rounders

## CNC Profile Ground, Double End



The Major Cut Dia. equals  
the Minor Dia. + (R. X 2) + .020

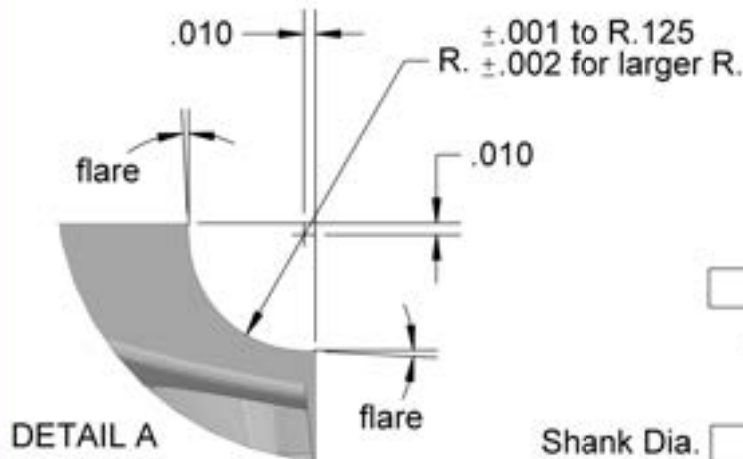
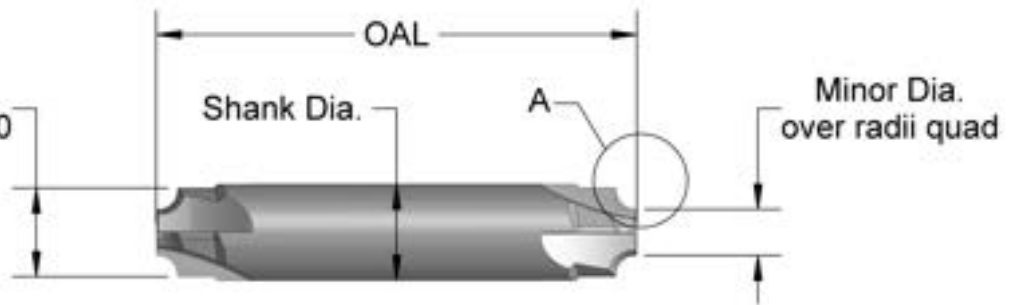

**Special Corner Rounders  
in 4-6 working days**  
Machining what part  
material, please?

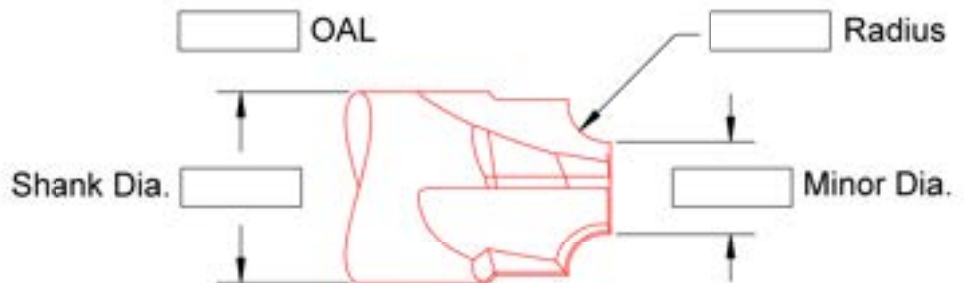

All AB Tools corner rounders  
are made with these features  
to avoid gouging.

Tool No.	(add R. to prefix, example CR12-031) Radius Sizes Available	Minor Dia.	No. Flutes	Shank & OAL	Prices	
					No-Coat	AlTiN
CR1-__	.010 .013 .015 .018 .020 .022 .025 .028 .031			3/8 x 2.5	\$95.	\$109.
	.035 .038 .040 .046 .048 .050 .055					
CR2-__	.062 .070 .078 .080 .085 .093 .098 .100 .109 .118 .120 .125	.240	4	1/2 x 2.5	\$115.	\$133.
	.140 .156 .170 .187			5/8 x 3.5	\$180.	\$206.
	.197 .203 .218 .234 .250			3/4 x 4.0	\$215.	\$245.
CR03-__	.010 .015 .020 .025 .031 .040 .046 .050 .055	.030	2	3/16 x 2	\$60.	\$67.
	.062 .070 .078					
CR06-__	.010 .013 .015 .018 .020 .022 .025 .028 .031 .035 .040	.060	2	3/16 x 2	\$60.	\$67.
	.046 .048 .050 .055 .060					
CR12-__	.010 .013 .015 .018 .020 .022 .025 .028 .031	.120	2	1/4 x 2	\$70.	\$78.
	.035 .038 .040 .046 .048 .050 .055 .060					
CR18-__	.015 .020 .031 .035 .046 .055 .062 .070 .078 .080	.180	3	3/8 x 2.5	\$95.	\$109.
	.085 .093 .098 .109 .118 .120 .125 .130 .135 .140 .150 .156			1/2 x 2.5	\$115.	\$133.
	.170 .180 .187 .197 .203 .218			5/8 x 3.5	\$180.	\$206.
	.234 .250			3/4 x 4.0	\$215.	\$245.



A. B. TOOLS, INC.  
1051 Aviation Blvd.  
Lincoln, CA 95648-9312

Phone 916 408-2442  
FAX 916 993-3949

www.abtoolsinc.com  
E-Mail: mail@abtoolsinc.com

# Extended Reach, Double End, Solid Carbide, Corner Rounders

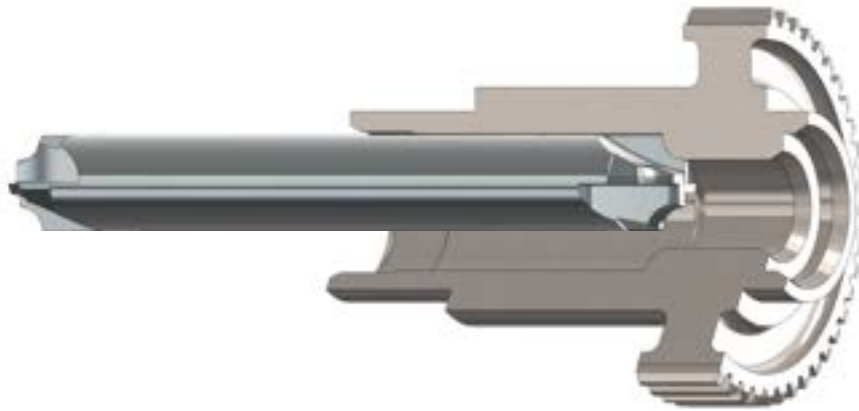

**Specials in 4-6 Working Days**

Radius center at shank diameter allows machining close to other features.

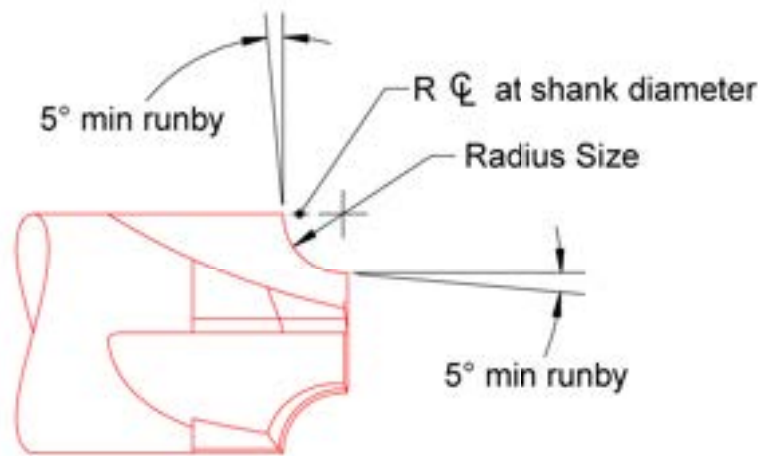

Number	Radius sizes, add to prefix, example CRL1/2-062							Shank & OAL	Flutes	Price	
CRL1/4-	.010	.015	.020	.031	.046	.062		1/4 X 3	2 or 4	\$95.	
CRL3/8-	.010	.015	.020	.031	.046	.062		3/8 X 4	2 or 4	\$115.	
	.093	.125						3/8 X 4	2 or 4		
CRL1/2-	.010	.015	.020	.031	.046	.062	.093	.125	1/2 X 4	2 or 4	\$135.
	.156	.187							1/2 X 4	2 or 4	



A. B. TOOLS, INC.  
1051 Aviation Blvd.  
Lincoln, CA 95648-9312

Phone 916 408-2442  
FAX 916 993-3949

www.abtoolsinc.com  
E-Mail: mail@abtoolsinc.com

# Solid Carbide TOP & BOTTOM Corner Rounders

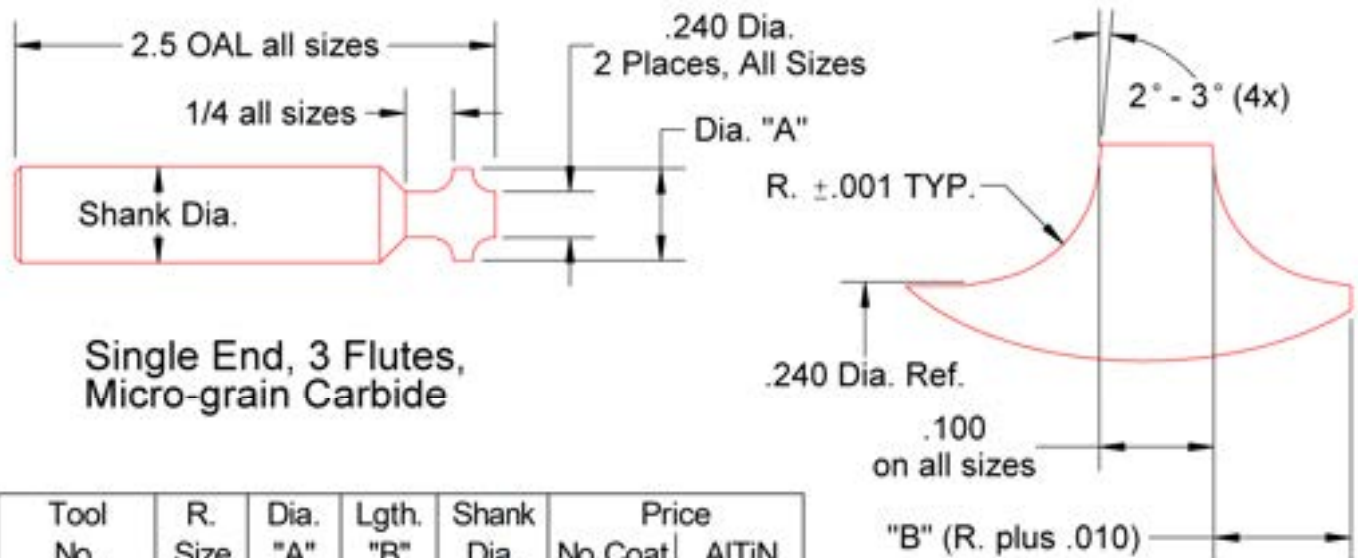

Single End, 3 Flutes,  
Micro-grain Carbide

Tool No.	R. Size	Dia. "A"	Lgth. "B"	Shank Dia.	Price	
					No Coat	AlTiN
CRD-015	.015	.290	.025	3/8	\$135.	\$142.
CRD-020	.020	.300	.030	3/8	\$135.	\$142.
CRD-031	.031	.322	.041	3/8	\$135.	\$142.
CRD-040	.040	.340	.050	3/8	\$135.	\$142.
CRD-046	.046	.352	.056	3/8	\$135.	\$142.
CRD-062	.062	.384	.072	1/2	\$150.	\$159.
CRD-078	.078	.416	.088	1/2	\$150.	\$159.
CRD-093	.093	.446	.103	1/2	\$150.	\$159.
CRD-109	.109	.478	.119	1/2	\$150.	\$159.
CRD-125	.125	.510	.135	1/2	\$150.	\$159.

**Specials in 4-6  
Working Days**



A. B. TOOLS, INC.  
1051 Aviation Blvd.  
Lincoln, CA 95648-9312

Phone 916 408-2442  
FAX 916 993-3949

www.abtoolsinc.com  
E-Mail: mail@abtoolsinc.com

# Solid Carbide BACK Corner Rounders

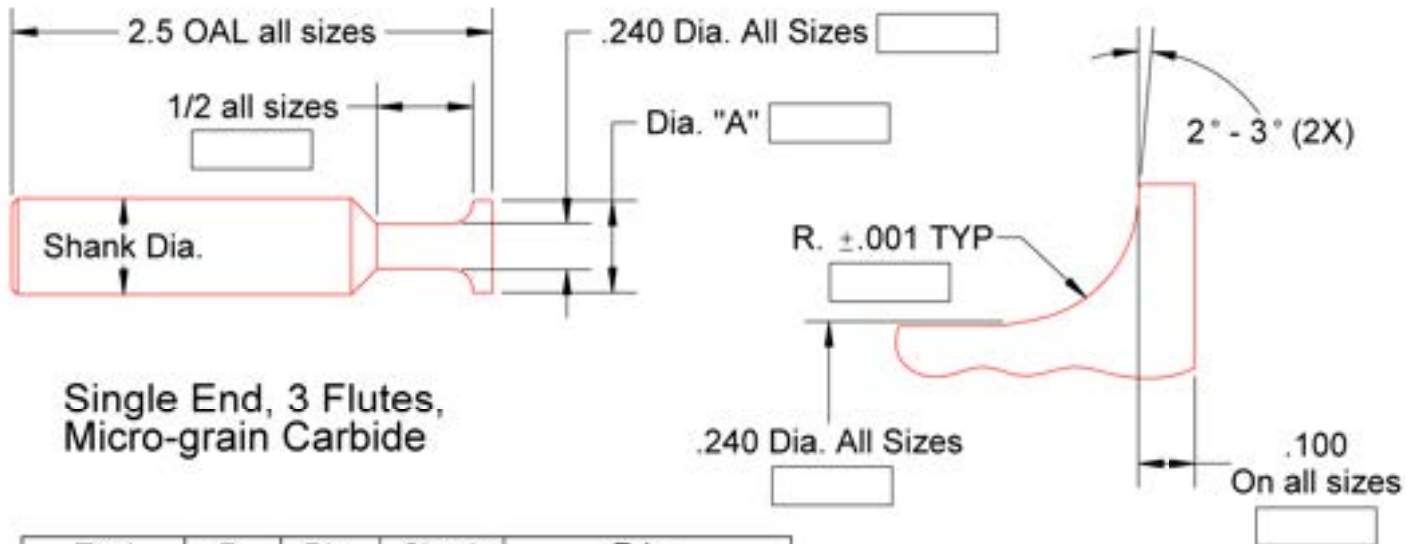

Single End, 3 Flutes,  
Micro-grain Carbide

Tool No.	R. Size	Dia. "A"	Shank Dia.	Price	
				No Coat	AlTiN
BCR-015	.015	.290	3/8	\$110.	\$117.
BCR-020	.020	.300	3/8	\$110.	\$117.
BCR-031	.031	.322	3/8	\$110.	\$117.
BCR-040	.040	.340	3/8	\$110.	\$117.
BCR-046	.046	.352	3/8	\$110.	\$117.
BCR-062	.062	.384	1/2	\$120.	\$129.
BCR-078	.078	.416	1/2	\$120.	\$129.
BCR-093	.093	.446	1/2	\$120.	\$129.
BCR-109	.109	.478	1/2	\$120.	\$129.
BCR-125	.125	.510	1/2	\$120.	\$129.

**Specials in 4-6 Working Days**



A. B. TOOLS, INC.  
1051 Aviation Blvd.  
Lincoln, CA 95648-9312

Phone 916 408-2442  
FAX 916 993-3949

www.abtoolsinc.com  
E-Mail: mail@abtoolsinc.com

# Solid Carbide Full Concave Cutters



Full Form Design

**Specials in 4-6 Working Days**



Alternating Tooth Design

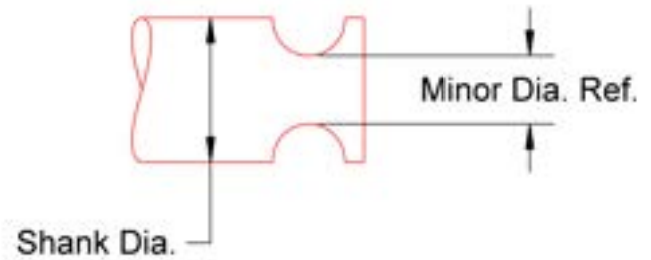
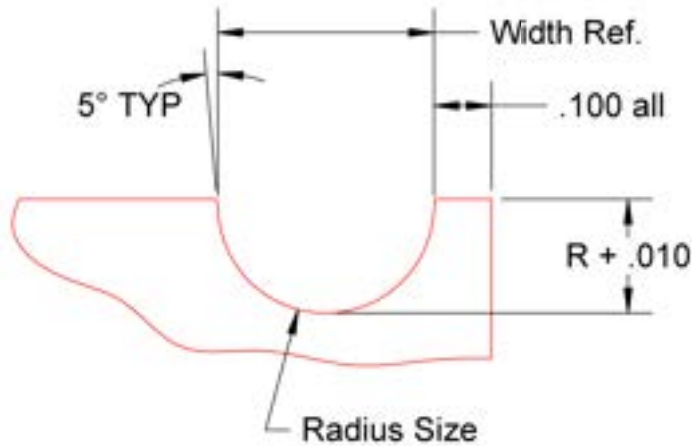

Profile ground (not formed) for rounder, more free cutting concave cutters.

Tool Number	Radius Size	Width Ref.	Shank X OAL	Number of Flutes	Minor Dia. Ref.	Price	
						No-Coat	AlTiN
FCR-031 *	.031	.062	1/2 X 2.5	6	.418	\$160.	\$169.
FCR-040 *	.040	.080	1/2 X 2.5	4	.400	\$160.	\$169.
FCR-046 *	.046	.092	1/2 X 2.5	4	.388	\$160.	\$169.
FCR-0625	.0625	.125	1/2 X 2.5	4	.355	\$170.	\$179.
FCR-079	.079	.158	1/2 X 2.5	4	.322	\$175.	\$184.
FCR-094	.094	.188	5/8 X 3.5	6	.417	\$205.	\$218.
FCR-100	.100	.200	5/8 X 3.5	4	.405	\$205.	\$218.
FCR-120	.120	.240	5/8 X 3.5	4	.365	\$210.	\$223.
FCR-125	.125	.250	5/8 X 3.5	4	.355	\$210.	\$223.
FCR-157	.157	.314	3/4 X 4.0	6	.416	\$235.	\$250.
FCR-1875	.1875	.375	3/4 X 4.0	4	.355	\$250.	\$265.
FCR-197	.197	.394	3/4 X 4.0	4	.336	\$250.	\$265.

\*Cutters with smaller radii are ground with alternating tooth design



A. B. TOOLS, INC.  
1051 Aviation Blvd.  
Lincoln, CA 95648-9312

Phone 916 408-2442  
FAX 916 993-3949

www.abtoolsinc.com  
E-Mail: mail@abtoolsinc.com

# Carbide Tipped Corner Rounders

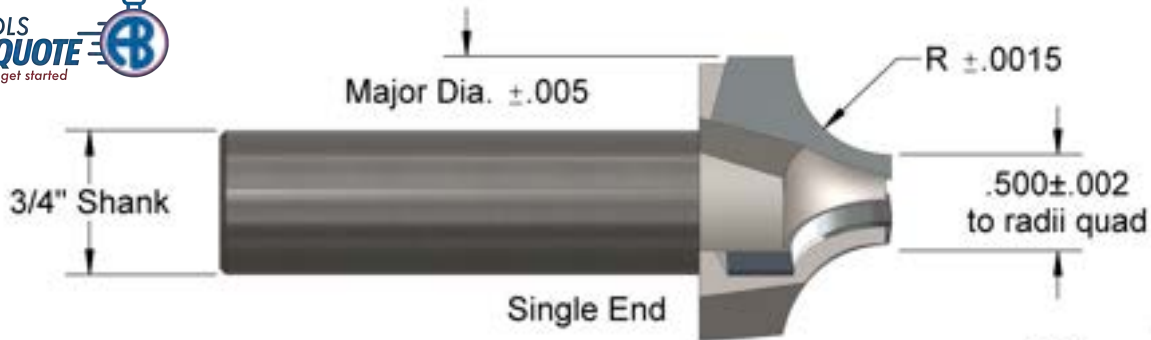

**Special Carbide Tipped Corner Rounders in 4-6 working days**

Machining what part material, please? \_\_\_\_\_

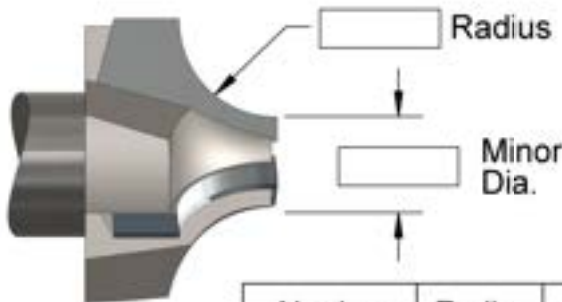

All AB Tools corner rounders are made with these features to avoid gouging.

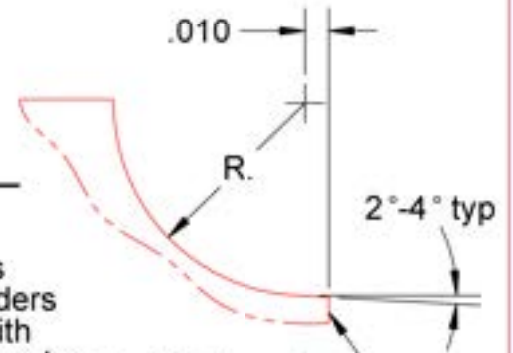

End Cutting, also the major Dia. is cutting for 1/8 min.

Number	Radius	Major Dia.	OAL	Price	
				No-Coat	AlTiN
3 Flutes, Positive Rake					
CR3-187	.187	.895	3.25	\$205.	\$226.
CR3-203	.203	.926		\$215.	\$236.
CR3-218	.218	.956		\$230.	\$251.
CR3-250	.250	1.020		\$235.	\$259.
CR3-281	.281	1.082		\$250.	\$274.
CR3-312	.312	1.144		\$260.	\$284.
CR3-343	.343	1.206		\$285.	\$309.
CR3-375	.375	1.270		\$310.	\$336.
CR3-406	.406	1.332		\$325.	\$351.
CR3-437	.437	1.394		\$335.	\$361.
CR3-468	.468	1.456	\$350.	\$376.	
CR3-500	.500	1.520	\$370.	\$402.	
CR3-562	.562	1.644	3.50	\$400.	\$432.
CR3-625	.625	1.770		\$445.	\$546.



A. B. TOOLS, INC.  
1051 Aviation Blvd.  
Lincoln, CA 95648-9312

Phone 916 408-2442  
FAX 916 993-3949

www.abtoolsinc.com  
E-Mail: mail@abtoolsinc.com



# Large Radii M42 Cobalt Corner Rounders

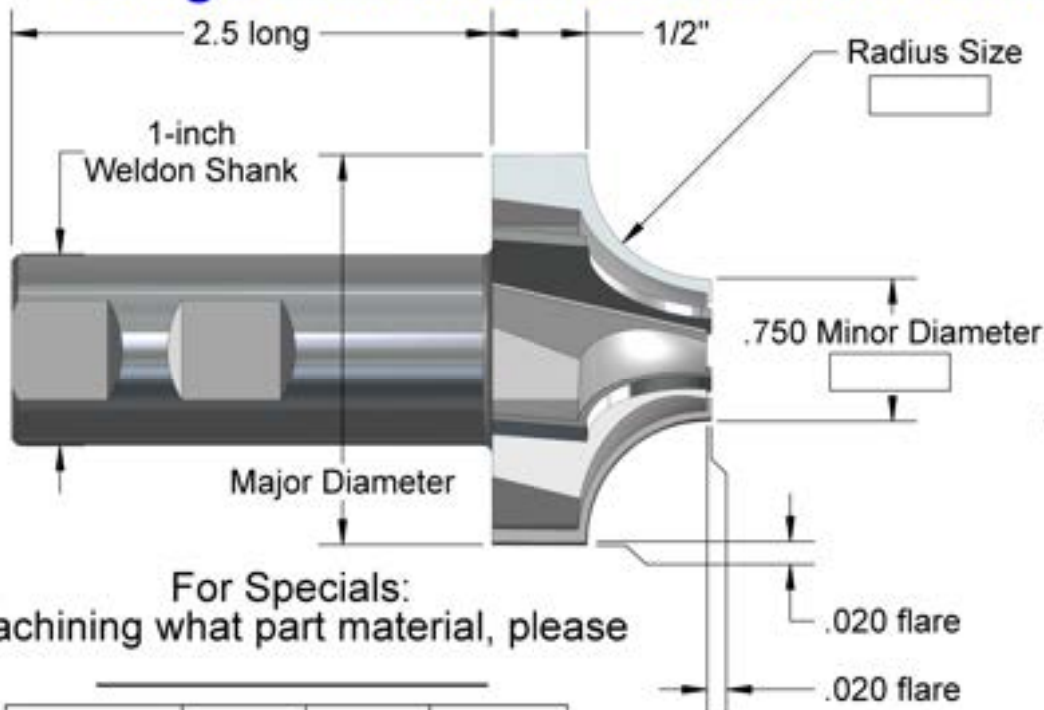

For Specials:  
Machining what part material, please

Number	Radius	Major Dia.	Price
CCR-625	.625	2.04	\$530.
CCR-687	.687	2.16	\$540.
CCR-719	.719	2.23	\$545.
CCR-750	.750	2.29	\$550.
CCR-787	.787	2.36	\$555.
CCR-812	.812	2.41	\$560.
CCR-875	.875	2.54	\$575.
CCR-937	.937	2.66	\$590.
CCR-984	.984	2.76	\$600.
CCR-1000	1.000	2.79	\$605.
CCR-1063	1.063	2.91	\$620.
CCR-1125	1.125	3.04	\$635.
CCR-1181	1.181	3.15	\$650.
CCR-1250	1.250	3.29	\$675.
CCR-1312	1.312	3.41	\$710.
CCR-1375	1.375	3.54	\$765.
CCR-1437	1.437	3.66	\$835.
CCR-1500	1.500	3.79	\$895.



We've milled full radius cuts with these Corner Rounders in M2 HSS at 90 SFM and .0015 Inch Per Tooth Chip Load with GREAT results

\*\*\*Coatings available upon request.



A. B. TOOLS, INC.  
1051 Aviation Blvd.  
Lincoln, CA 95648-9312

Phone 916 408-2442  
FAX 916 993-3949

www.abtoolsinc.com  
E-Mail: mail@abtoolsinc.com

# Solid Carbide Thread Mills



With these 12 cutters you can mill Coarse or Fine threads from No. 3 thru 3/4 and from 2MM thru 24MM

Number	For Sizes (NC & NF)		Cut Dia.	Crest	Neck Dia.	Neck* Length	Shank & OAL	No. of Flutes	Price	
									No-Coat	AlTiN
TM3	#3	2MM	.072	.001	.040	.160	3/16 X 2	1	\$65.	\$69.
TM4	#4	3MM	.083	.001	.045	.190	3/16 X 2	1	\$65.	\$69.
	#5	3.5MM								
TM6	#6	4MM	.099	.0015	.055	.260	3/16 X 2	2	\$65.	\$69.
TM8	#8	4.5MM	.128	.002	.083	.320	3/16 X 2	3	\$70.	\$74.
TM10	#10	5MM	.139	.0025	.081	.380	3/16 X 2	3	\$70.	\$74.
TM1/4	1/4	6MM	.188	.003	.124	.400	1/4 X 2	4	\$75.	\$79.
TM5/16	5/16	8MM	.247	.003	.175	.500	3/8 X 2.5	4	\$85.	\$92.
TM3/8	3/8	10MM	.300	.003	.218	.600	3/8 X 2.5	4	\$90.	\$97.
TM7/16	7/16	12MM	.330	.0035	.184	.660	3/8 X 2.5		\$95.	\$102.
TM1/2	1/2	16MM	.420	.0035	.300	.800	1/2 X 2.5	6	\$110.	\$119.
TM5/8	5/8	20MM	.500	.0026	.307	1.00	5/8 X 3.5	6	\$155.	\$168.
TM3/4	3/4	24MM	.625	.0026	.416	1.25	3/4 X 4	6	\$210.	\$225.

\*Necks ground longer on request with minimal charges based upon quantity

**Special Thread Mills in 4-6 Working Days**  
Machining what part material, please?

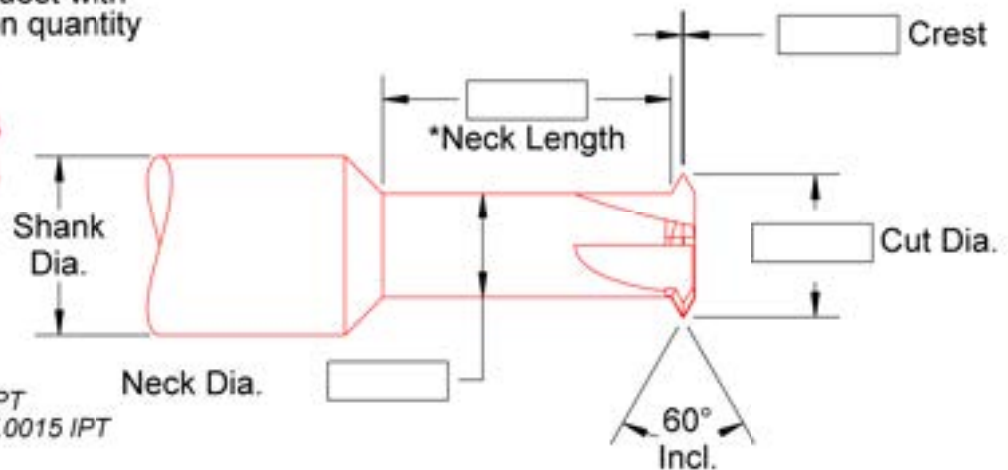

*Suggested Starting Data:*  
Ferrous 150/300 SFM; .0002/.001 IPT  
Non-Ferrous 500/1000 SFM; .0005/.0015 IPT  
Interpolate helix from bottom up.



A. B. TOOLS, INC.  
1051 Aviation Blvd.  
Lincoln, CA 95648-9312

Phone 916 408-2442  
FAX 916 993-3949

www.abtoolsinc.com  
E-Mail: mail@abtoolsinc.com

# NEW !!! ACME Thread Mills NEW !!!



Number	TPI	Cutter Dia.	Flat Size	Neck Dia.	Neck Length	Shank Dia.	OAL	No of Flutes	Price
TM-16ATM	16	.178	.0206	.075	1/4"	1/4"	2"	3	\$80.
TM-14ATM	14	.231	.0239	.100	3/8"	1/4"	2-1/2"	3	\$85.
TM-12ATM	12	.282	.0283	.138	1/2"	5/16"	2-1/2"	3	\$105.
TM-10ATM	10	.375	.0319	.200	5/8"	3/8"	2-1/2"	5	\$125.
TM-8ATM	8	.480	.0411	.275	3/4"	1/2"	3"	5	\$140.
TM-6ATM	6	.543	.0566	.297	1"	5/8"	3-1/2"	5	\$185.
TM-5ATM	5	.750	.0689	.446	1-1/4"	3/4"	5"	5	\$235.
TM-4ATM	4	.750	.0875	.396	1-1/2"	3/4"	5"	5	\$250.

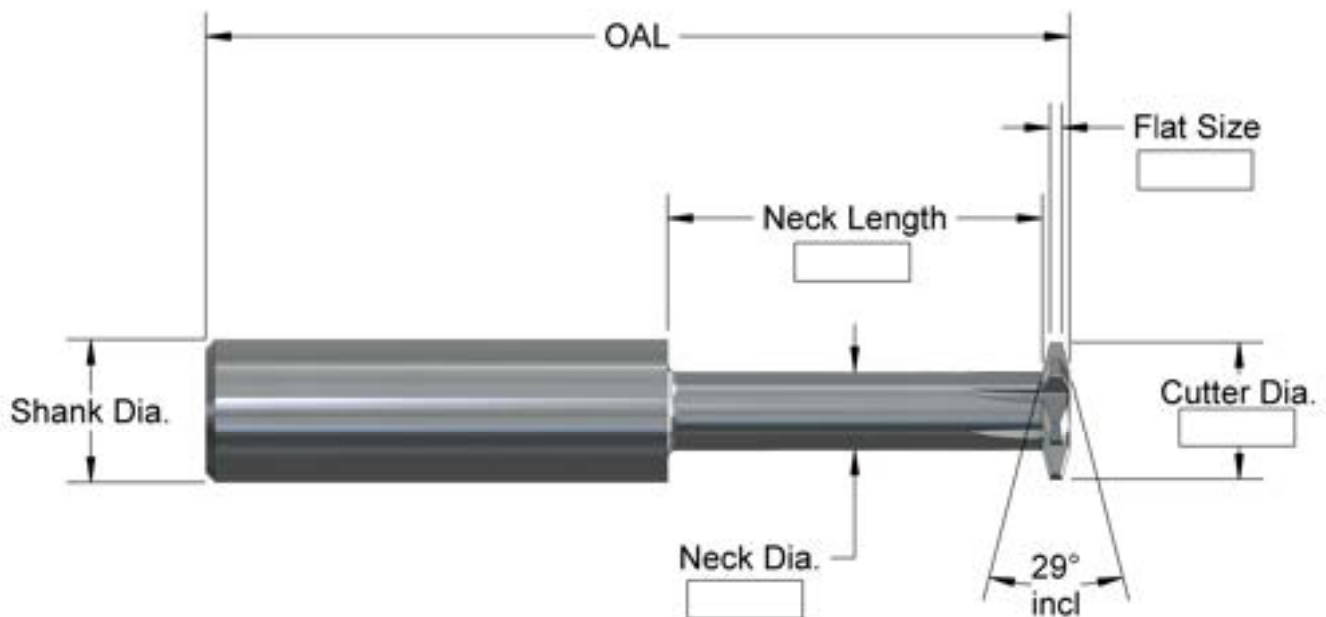

A. B. TOOLS, INC.  
1051 Aviation Blvd.  
Lincoln, CA 95648-9312

Phone 916 408-2442  
FAX 916 993-3949

www.abtoolsinc.com  
E-Mail: mail@abtoolsinc.com

# Solid Carbide Internal Thread Relief Mills



Number	Dia.	Flat	Rad.	Neck Dia.	Neck Length	Shank Dia.	OAL	No. of Flutes	Price	
									No-Coat	AlTiN
TR3-48	.072	.021	.005	.032	.180	3/16	2	2	\$65.	\$69.
TR4-40	.080	.025	.005	.032	.210	3/16	2	2	\$65.	\$69.
TR6-32	.099	.031	.010	.047	.290	3/16	2	2	\$65.	\$69.
TR8-32	.128	.031	.010	.076	.330	3/16	2	3	\$65.	\$69.
TR10-24	.139	.042	.012	.073	.410	3/16	2	3	\$65.	\$69.
TR1/4-20	.188	.050	.012	.108	.435	1/4	2	4	\$70.	\$74.
TR5/16-18	.247	.056	.012	.159	.538	3/8	2-1/2	4	\$80.	\$87.
TR3/8-16	.300	.063	.012	.202	.641	3/8	2-1/2	4	\$90.	\$97.
TR1/2-13	.420	.077	.012	.284	.848	1/2	2-1/2	6	\$105.	\$114.

\*Necks ground longer on request with minimal charges based upon quantity

Undercut diameter:  
 Pitches finer than 20 TPI = thread basic major dia + .0075  
 Pitches of 20 TPI and courser = thread basic major dia + .0150

## Special Thread Relief Mills Made in 4-6 Working Days

Machining what part material, please? \_\_\_\_\_

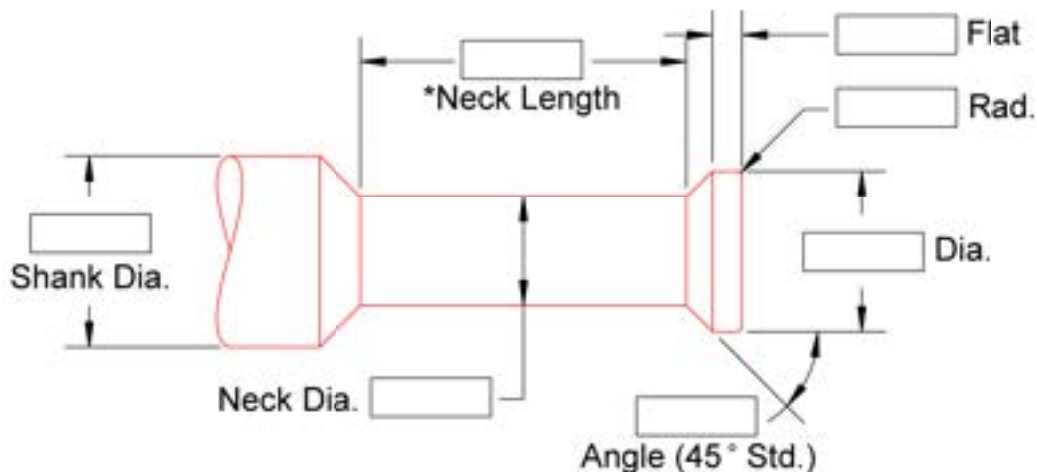

A. B. TOOLS, INC.  
 1051 Aviation Blvd.  
 Lincoln, CA 95648-9312

Phone 916 408-2442  
 FAX 916 993-3949

www.abtoolsinc.com  
 E-Mail: mail@abtoolsinc.com

# Bevel Cutters, Solid Carbide, In Stock.

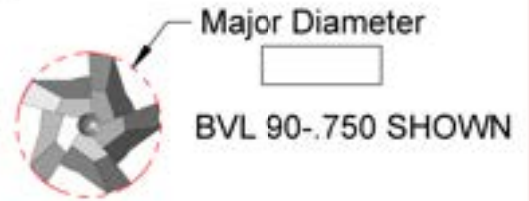
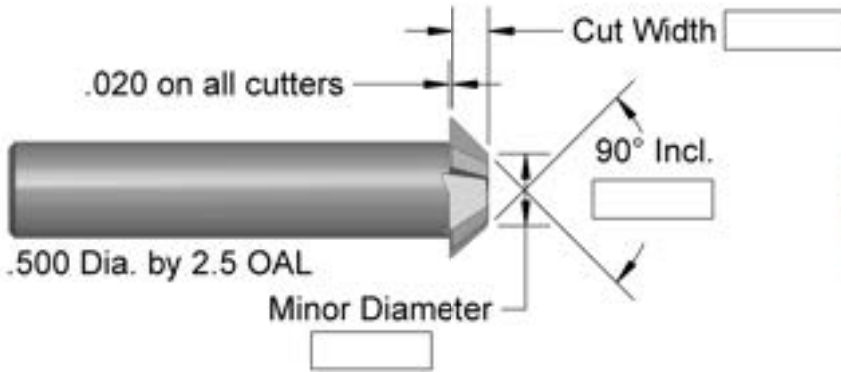

**Specials in 4-6 Working Days**

## 90° Included Angles

Number	Major Diameter	Minor Diameter	Cut Width	Number of Flutes	Price
BVL 90-.500	.500	.250	.125	4	\$110.
BVL 90-.750	.750	.375	.188	5	\$135.
BVL 90-1.00	1.000	.375	.312	6	\$165.
BVL 90-1.25	1.250	.500	.375	8	\$195.
BVL 90-1.50*	1.500	.500	.500	10	\$235.

## 60° Included Angles

Number	Major Diameter	Minor Diameter	Cut Width	Number of Flutes	Price
BVL 60-.500	.500	.246	.220	4	\$110.
BVL 60-.750	.750	.390	.312	5	\$135.
BVL 60-1.00	1.000	.503	.430	6	\$165.
BVL 60-1.25*	1.250	.673	.500	8	\$195.
BVL 60-1.50*	1.500	.778	.625	10	\$235.

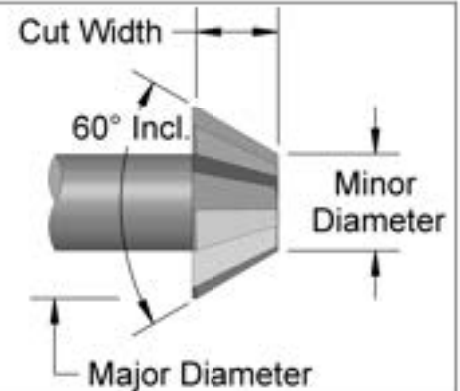

## 120° Included Angles

Number	Major Diameter	Minor Diameter	Cut Width	Number of Flutes	Price
BVL 120-.500	.500	.188	.090	4	\$110.
BVL 120-.750	.750	.317	.125	5	\$135.
BVL 120-1.00	1.000	.350	.188	6	\$165.
BVL 120-1.25	1.250	.488	.220	8	\$195.
BVL 120-1.50	1.500	.634	.250	10	\$235.

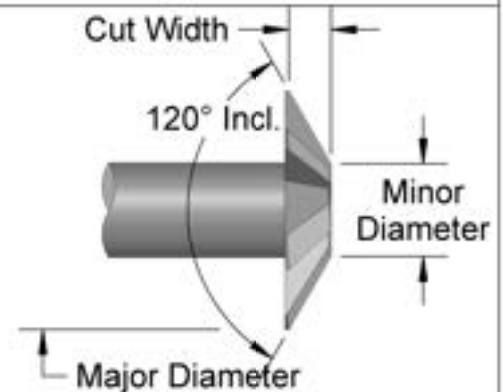

\* These cutters are on 3/4" shanks and 2-3/4" OAL



A. B. TOOLS, INC.  
1051 Aviation Blvd.  
Lincoln, CA 95648-9312

Phone 916 408-2442  
FAX 916 993-3949

www.abtoolsinc.com  
E-Mail: mail@abtoolsinc.com

# Solid Carbide TOP & BOTTOM Chamfer Cutters

## Specials in 4-6 Working Days

Machining what part material, please? \_\_\_\_\_

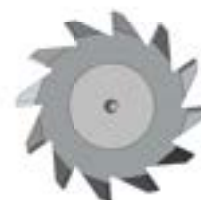
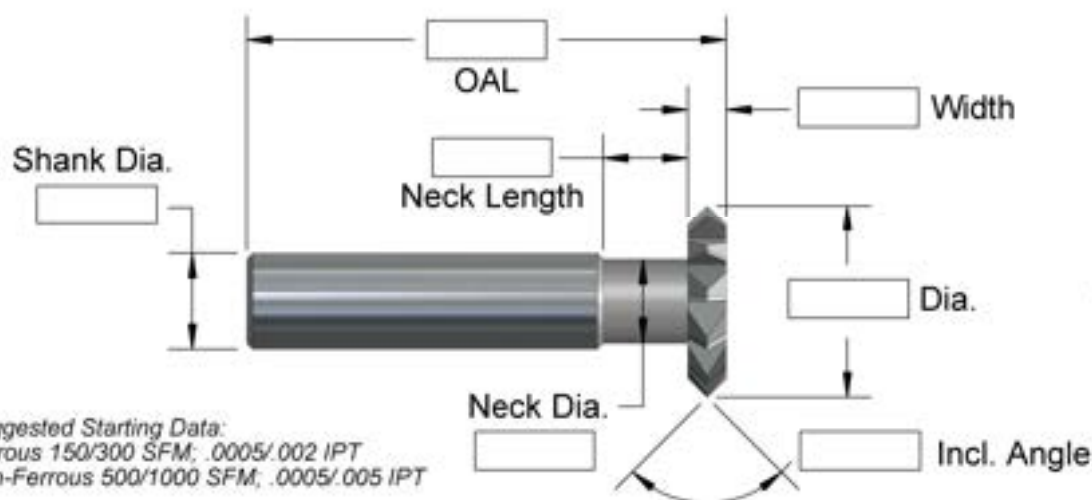

Suggested Starting Data:  
 Ferrous 150/300 SFM; .0005/.002 IPT  
 Non-Ferrous 500/1000 SFM; .0005/.005 IPT

Number	Dia.	Width	Neck Dia.	Neck Length	Incl. Angle	Shank & OAL	No. of Flutes	Price	
								No-Coat	AlTiN
CCD-187-90	.187	.060	.115	.38	90	3/16-2	4	\$68.	\$72.
CCD-250-90	.250	.090	.150	.44	90	1/4-2	4	\$80.	\$84.
CCD-375-90	.375	.110	.250	.50	90	3/8-2.5	6	\$100.	\$107.
CCD-500-90	.500	.125	.350	.68	90	1/2-2.5	6	\$120.	\$129.
CCD-625-90	.625	.140	As Cast		90	1/2-2.5	8	\$145.	\$155.
CCD-750-90	.750	.170	As Cast		90	1/2-2.5	10	\$160.	\$172.
CCD-100-90	1.00	.200	As Cast		90	1/2-2.5	12	\$190.	\$204.
CCD-187-60	.187	.030	.115	.38	60	3/16-2	4	\$68.	\$72.
CCD-250-60	.250	.045	.150	.44	60	1/4-2	4	\$80.	\$84.
CCD-375-60	.375	.060	.250	.50	60	3/8-2.5	6	\$100.	\$107.
CCD-500-60	.500	.075	.350	.68	60	1/2-2.5	6	\$120.	\$129.
CCD-625-60	.625	.090	As Cast		60	1/2-2.5	8	\$145.	\$155.
CCD-750-60	.750	.150	As Cast		60	1/2-2.5	10	\$160.	\$172.
CCD-100-60	1.00	.200	As Cast		60	1/2-2.5	12	\$190.	\$204.
CCD-187-120	.187	.060	.115	.38	120	3/16-2	4	\$68.	\$72.
CCD-250-120	.250	.090	.150	.44	120	1/4-2	4	\$80.	\$84.
CCD-375-120	.375	.110	.250	.50	120	3/8-2.5	6	\$100.	\$107.
CCD-500-120	.500	.125	.350	.68	120	1/2-2.5	6	\$120.	\$129.
CCD-625-120	.625	.140	As Cast		120	1/2-2.5	8	\$145.	\$155.
CCD-750-120	.750	.170	As Cast		120	1/2-2.5	10	\$160.	\$172.
CCD-100-120	1.00	.200	As Cast		120	1/2-2.5	12	\$190.	\$204.



A. B. TOOLS, INC.  
 1051 Aviation Blvd.  
 Lincoln, CA 95648-9312

Phone 916 408-2442  
 FAX 916 993-3949

www.abtoolsinc.com  
 E-Mail: mail@abtoolsinc.com

# Solid Carbide Chamfer End Mills

**Specials in 4-6 Working Days**

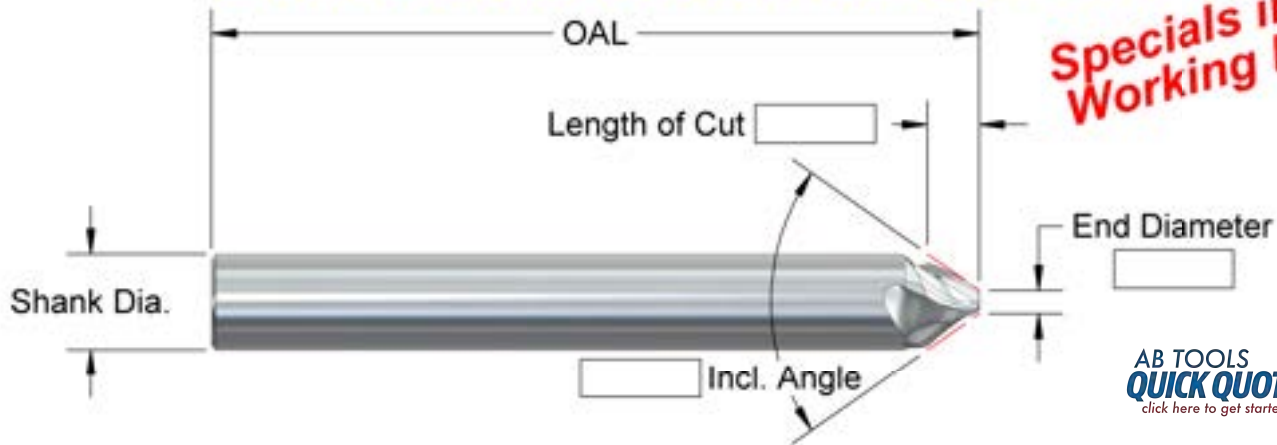

Number	End Dia.	Incl. Angle	Length of Cut	Shank X OAL	No. of Flutes	Price	
						No-Coat	AlTiN
CEM060-70	.060	70°	.136	1/4 X 2.0	3	\$75.	\$79.
CEM060-74	.060	74°	.126	1/4 X 2.0	3	\$75.	\$79.
CEM060-80	.060	80°	.113	1/4 X 2.0	3	\$75.	\$79.
CEM060-82	.060	82°	.109	1/4 X 2.0	3	\$75.	\$79.
CEM060-90	.060	90°	.095	1/4 X 2.0	3	\$75.	\$79.
CEM060-100	.060	100°	.080	1/4 X 2.0	3	\$75.	\$79.
CEM060-120	.060	120°	.091	3/8 X 2.5	3	\$85.	\$92.
CEM120-70	.120	70°	.182	3/8 X 2.5	3	\$85.	\$92.
CEM120-74	.120	74°	.169	3/8 X 2.5	3	\$85.	\$92.
CEM120-80	.120	80°	.152	3/8 X 2.5	3	\$85.	\$92.
CEM120-82	.120	82°	.147	3/8 X 2.5	3	\$85.	\$92.
CEM120-90	.120	90°	.128	3/8 X 2.5	3	\$85.	\$92.
CEM120-100	.120	100°	.107	3/8 X 2.5	3	\$85.	\$92.
CEM120-120	.120	120°	.110	1/2 X 2.5	3	\$100.	\$109.
CEM180-70	.180	70°	.229	1/2 X 2.5	3	\$100.	\$109.
CEM180-74	.180	74°	.212	1/2 X 2.5	3	\$100.	\$109.
CEM180-80	.180	80°	.191	1/2 X 2.5	3	\$100.	\$109.
CEM180-82	.180	82°	.184	1/2 X 2.5	3	\$100.	\$109.
CEM180-90	.180	90°	.160	1/2 X 2.5	3	\$100.	\$109.
CEM180-100	.180	100°	.134	1/2 X 2.5	3	\$100.	\$109.
CEM180-120	.180	120°	.128	5/8 X 3.0	3	\$115.	\$127.

These are stocked with helical flutes. Positive axial rake is an option, same price. Ask for the same tool with -AX at the end of the tool number. eg: CEM120-90-AX



A. B. TOOLS, INC.  
1051 Aviation Blvd.  
Lincoln, CA 95648-9312

Phone 916 408-2442  
FAX 916 993-3949

www.abtoolsinc.com  
E-Mail: mail@abtoolsinc.com

# Solid Carbide Taper End Mills

(3) Flutes

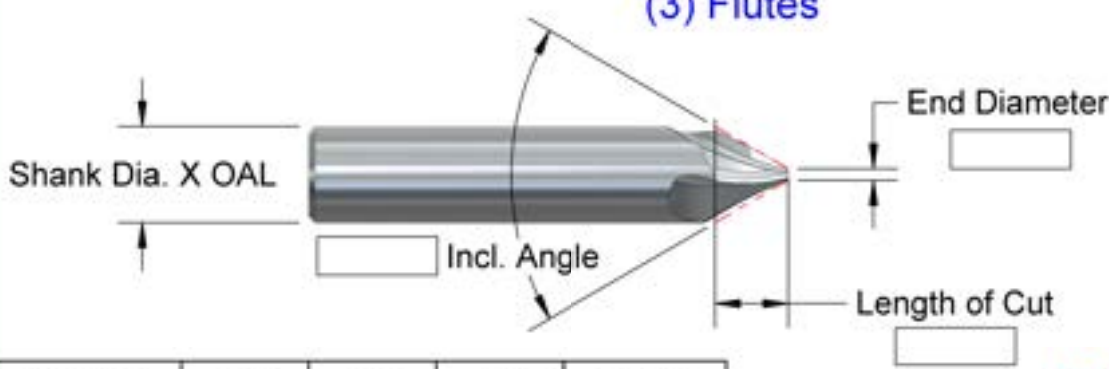

**Specials in 4-6 Working Days**

Number	End Dia.	Incl. Angle	Length of Cut	Shank X OAL
TEM060-10	.060	10°	.729	3/16 X 2.5
TEM060-12	.060	12°	.607	3/16 X 2.5
TEM060-15	.060	15°	.484	3/16 X 2.5
TEM060-20	.060	20°	.893	3/8 X 2.5
TEM060-25	.060	25°	.710	3/8 X 2.5
TEM060-30	.060	30°	.588	3/8 X 2.5
TEM060-35	.060	35°	.500	3/8 X 2.5
TEM060-40	.060	40°	.604	1/2 X 2.5
TEM060-45	.060	45°	.531	1/2 X 2.5
TEM060-50	.060	50°	.472	1/2 X 2.5
TEM060-60	.060	60°	.381	1/2 X 2.5

Shank X OAL	Price	
	No-Coat	AlTiN
3/16 X 2.5	\$75.	\$79.
1/4 X 2.5	\$75.	\$81.
3/8 X 2.5	\$90.	\$97.
1/2 X 2.5	\$100.	\$109.
1/2 X 3	\$105.	\$114.
1/2 X 4	\$115.	\$126.

Number	End Dia.	Incl. Angle	Length of Cut	Shank X OAL
TEM120-10	.120	10°	.743	1/4 X 2.5
TEM120-12	.120	12°	.618	1/4 X 2.5
TEM120-15	.120	15°	.494	1/4 X 2.5
TEM120-20	.120	20°	.723	3/8 X 2.5
TEM120-25	.120	25°	.575	3/8 X 2.5
TEM120-30	.120	30°	.476	3/8 X 2.5
TEM120-35	.120	35°	.404	3/8 X 2.5
TEM120-40	.120	40°	.522	1/2 X 2.5
TEM120-45	.120	45°	.459	1/2 X 2.5
TEM120-50	.120	50°	.407	1/2 X 2.5
TEM120-60	.120	60°	.329	1/2 X 2.5

Number	End Dia.	Incl. Angle	Length of Cut	Shank X OAL
TEM180-10	.180	10°	1.829	1/2 X 4
TEM180-12	.180	12°	1.522	1/2 X 4
TEM180-15	.180	15°	1.215	1/2 X 3
TEM180-20	.180	20°	.907	1/2 X 3
TEM180-25	.180	25°	.722	1/2 X 3
TEM180-30	.180	30°	.597	1/2 X 3
TEM180-35	.180	35°	.507	1/2 X 2.5
TEM180-40	.180	40°	.440	1/2 X 2.5
TEM180-45	.180	45°	.386	1/2 X 2.5
TEM180-50	.180	50°	.343	1/2 X 2.5
TEM180-60	.180	60°	.277	1/2 X 2.5



A. B. TOOLS, INC.  
1051 Aviation Blvd.  
Lincoln, CA 95648-9312

Phone 916 408-2442  
FAX 916 993-3949

www.abtoolsinc.com  
E-Mail: mail@abtoolsinc.com



# NEW !!! Lollipop Undercut End Mills NEW !!!

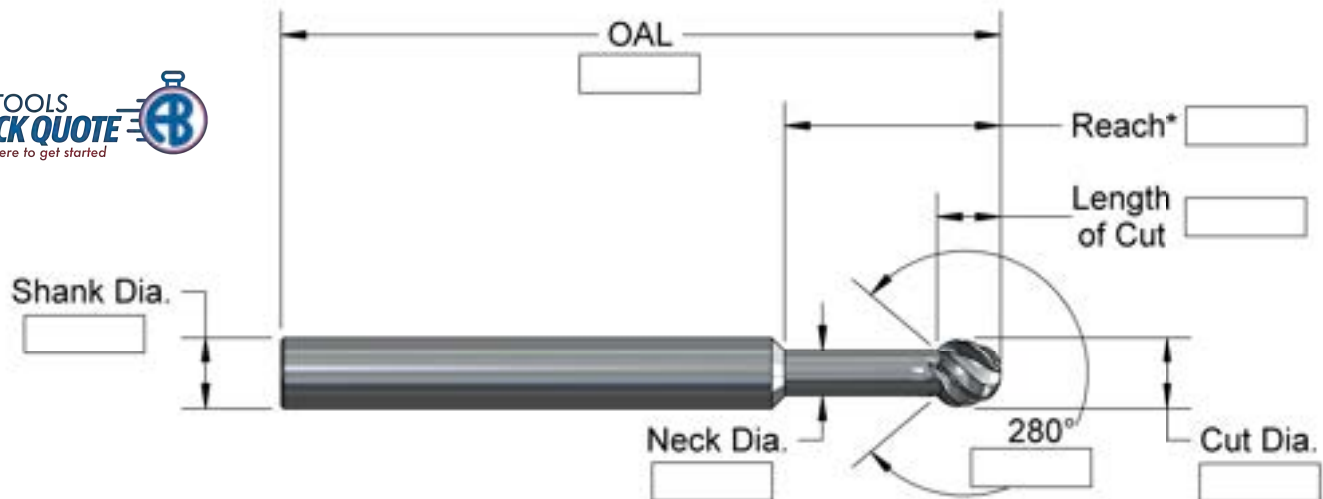

\* Longer necks can be ground in 1 work day

Tool No.	Cut Dia.	Length of Cut	Neck Dia.	Reach	Shank Dia.	OAL	No. of Flutes	Price
BE040-280	.040	.035	.026	.120	1/8"	2.0	4	\$75.
BE050-280	.050	.044	.032	.150	1/8"	2.0	4	\$75.
BE062-280	.062	.055	.040	.190	1/8"	2.0	4	\$70.
BE078-280	.078	.069	.050	.235	1/8"	2.0	4	\$70.
BE093-280	.093	.082	.060	.280	1/8"	2.0	4	\$70.
BE110-280	.110	.097	.071	.330	1/8"	2.0	4	\$70.
BE118-280	.118	.104	.076	.355	1/8"	2.0	4	\$70.
BE125-280	.125	.110	.080	.375	1/8"	2.0	4	\$70.
BE140-280	.140	.124	.090	.420	3/16"	2.0	4	\$85.
BE156-280	.156	.138	.100	.470	3/16"	2.0	4	\$85.
BE187-280	.187	.165	.120	.565	3/16"	2.0	4	\$85.
BE197-280	.197	.174	.127	.595	1/4"	2.5	4	\$95.
BE218-280	.218	.192	.140	.655	1/4"	2.5	4	\$95.
BE236-280	.236	.208	.152	.710	1/4"	2.5	4	\$95.
BE250-280	.250	.221	.161	.750	1/4"	2.5	4	\$95.
BE281-280	.281	.248	.181	.845	5/16"	2.5	4	\$115.
BE312-280	.312	.276	.201	.940	5/16"	2.5	6	\$115.
BE340-280	.340	.300	.219	1.020	3/8"	2.5	6	\$125.
BE375-280	.375	.331	.241	1.125	3/8"	2.5	6	\$125.
BE393-280	.393	.347	.253	1.180	1/2"	2.5	6	\$185.
BE437-280	.437	.386	.281	1.315	1/2"	2.5	6	\$185.
BE500-280	.500	.442	.321	1.500	1/2"	2.5	8	\$185.
BE530-280	.530	.468	.341	1.590	5/8"	3.5	8	\$235.
BE562-280	.562	.496	.361	1.690	5/8"	3.5	8	\$235.
BE625-280	.625	.552	.402	1.875	5/8"	3.5	8	\$235.
BE750-280	.750	.662	.482	2.250	3/4"	5.0	8	\$295.



A. B. TOOLS, INC.  
1051 Aviation Blvd.  
Lincoln, CA 95648-9312

Phone 916 408-2442  
FAX 916 993-3949

www.abtoolsinc.com  
E-Mail: mail@abtoolsinc.com

# Reduced Shank Solid Carbide End Mills

**NEW !!!** from .140 to 1.0 diameters **NEW !!!**  
with your decimal width in 4-6 working days

Machining what part material, please? \_\_\_\_\_

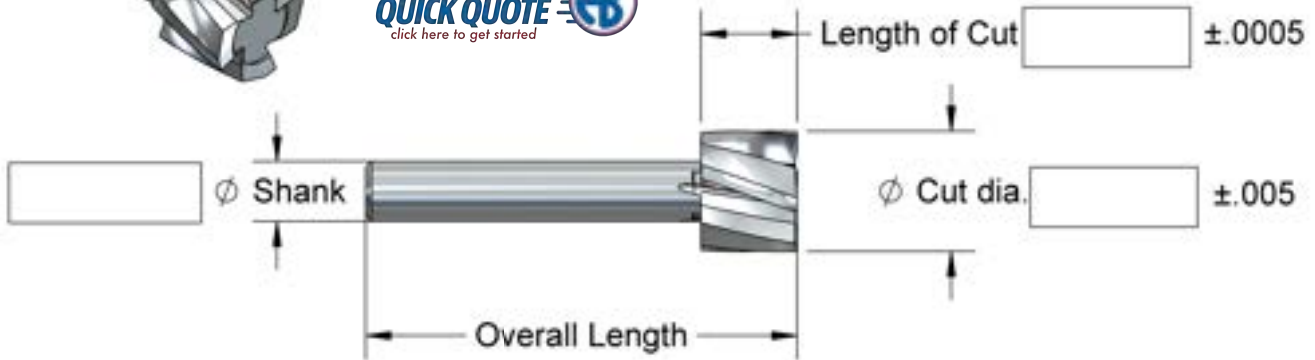

### Lollipop Style

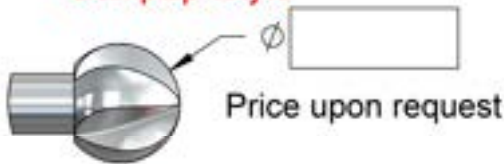

### Taper/Chamfer



### Ballnose Style

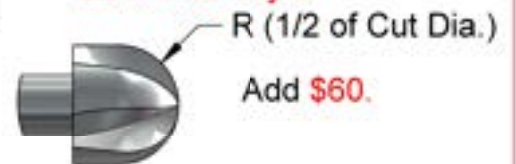

### Corner Radius

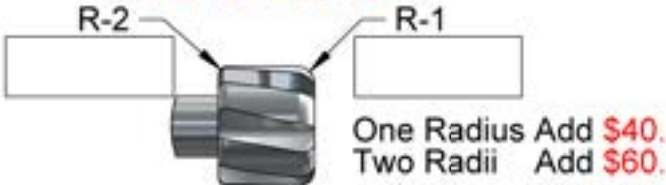

### Slot plus Top Chamfers

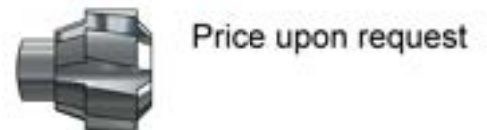

∅ Shank	OAL	Cut Diameter	Length of Cut Max	Basic Prices
1/8"	1-1/2"	.140 - .250	.250	<b>\$110.</b>
3/16"	1-1/2"	.195 - .375	.375	<b>\$120.</b>
1/4"	2"	.260 - .500	.500	<b>\$135.</b>
5/16"	2-1/4"	.320 - .625	.625	<b>\$150.</b>
3/8"	2-1/2"	.390 - .750	.750	<b>\$180.</b>
1/2"	3"	.515 - 1.0	1.0	<b>\$195.</b>



A. B. TOOLS, INC.  
1051 Aviation Blvd.  
Lincoln, CA 95648-9312

Phone 916 408-2442  
FAX 916 993-3949

www.abtoolsinc.com  
E-Mail: mail@abtoolsinc.com

# NEW !!! TOP HAT REMOVAL TOOL NEW !!!

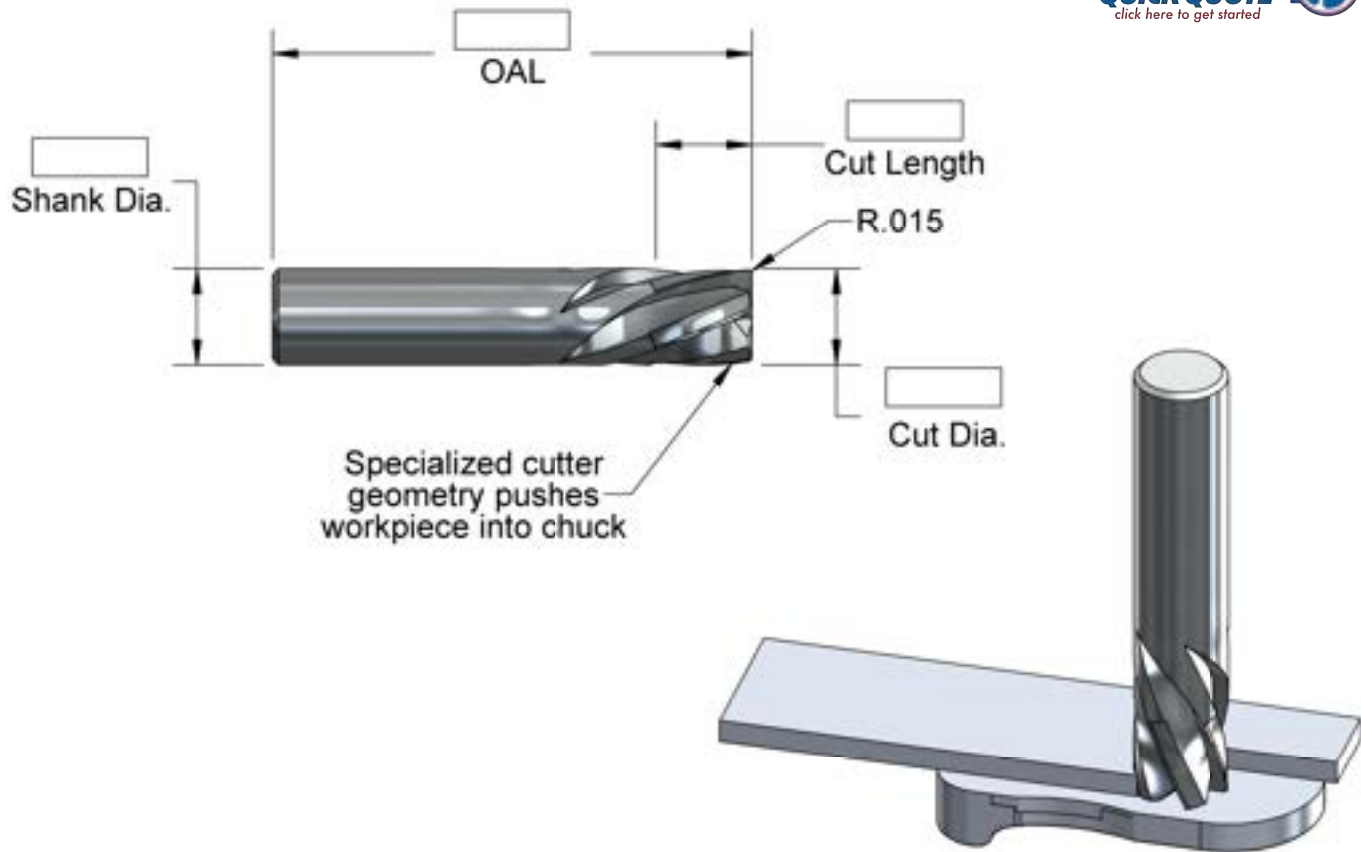

Number	Cut Dia.	Cut Length	Shank Dia.	OAL	No. of Flutes	Price	AlTiN
SEM25-30LH	.250	.250	1/4	2.0	3	\$60.	\$64.
SEM375-30LH	.375	.375	3/8	2.5	5	\$71.	\$78.
SEM5-30LH	.500	.500	1/2	2.5	5	\$79.	\$88.
SEM625-30LH	.625	.625	5/8	3.0	6	\$105.	\$115.
SEM75-30LH	.750	.750	3/4	4.0	8	\$150.	\$163.
SEM1-30LH	1.0	1.0	1.0	4.0	9	\$222.	\$242.
SEM125-30LH	1.250	1.250	1-1/4	4.5	9	\$320.	\$345.



A. B. TOOLS, INC.  
1051 Aviation Blvd.  
Lincoln, CA 95648-9312

Phone 916 408-2442  
FAX 916 993-3949

www.abtoolsinc.com  
E-Mail: mail@abtoolsinc.com

# Angle Reference and Standard Flats

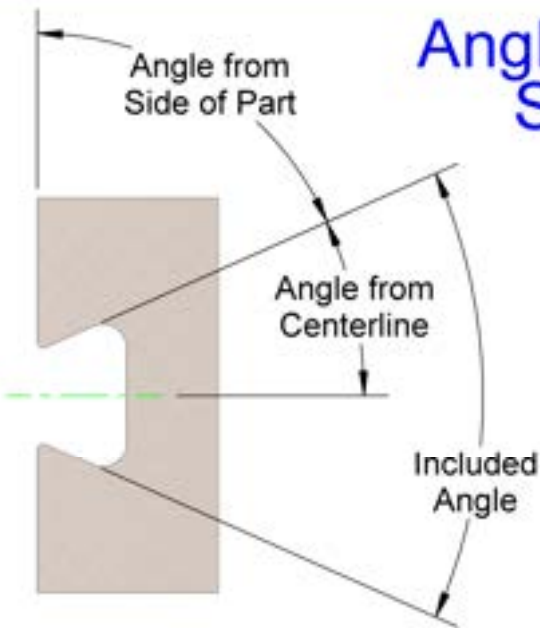

## Part Angles

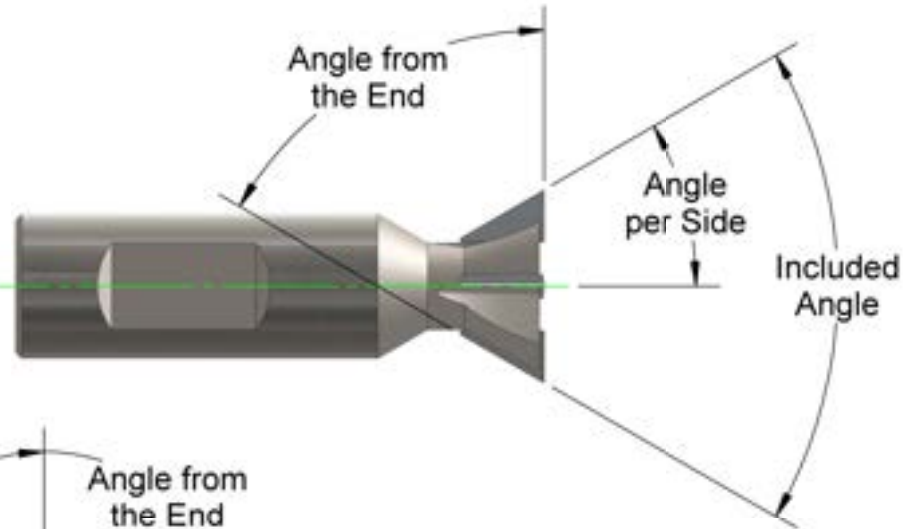

## Angles on a Dovetail Style Cutter

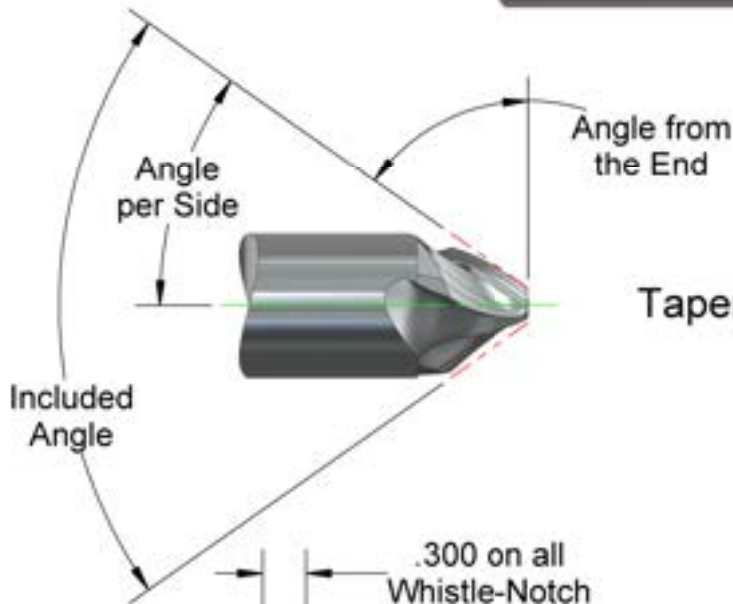

## Angles on a Taper End Mill or Chamfer Mill Style Cutter



Shank	Flat	"Y"	"X"	Depth	S/L	W/N
3/8	.280		.781	.050	1.56	1.0
1/2	.330		.890	.065	1.78	1.06
5/8	.400		.953	.070	1.90	1.19
3/4	.455		1.015	.075	2.03	1.25
7/8	.455	.50	1.015	.075	2.03	1.25
1.0	.515	.50	1.140	.075	2.28	1.44
1-1/4	.515	.50	1.140	.095	2.28	1.44



A. B. TOOLS, INC.  
1051 Aviation Blvd.  
Lincoln, CA 95648-9312

Phone 916 408-2442  
FAX 916 993-3949

www.abtoolsinc.com  
E-Mail: mail@abtoolsinc.com

# NEW !!! Solid Carbide Dovetail Cutters from .750 to 1.5 diameters NEW !!!

Custom specials upon request.



Machining what part material, please? \_\_\_\_\_

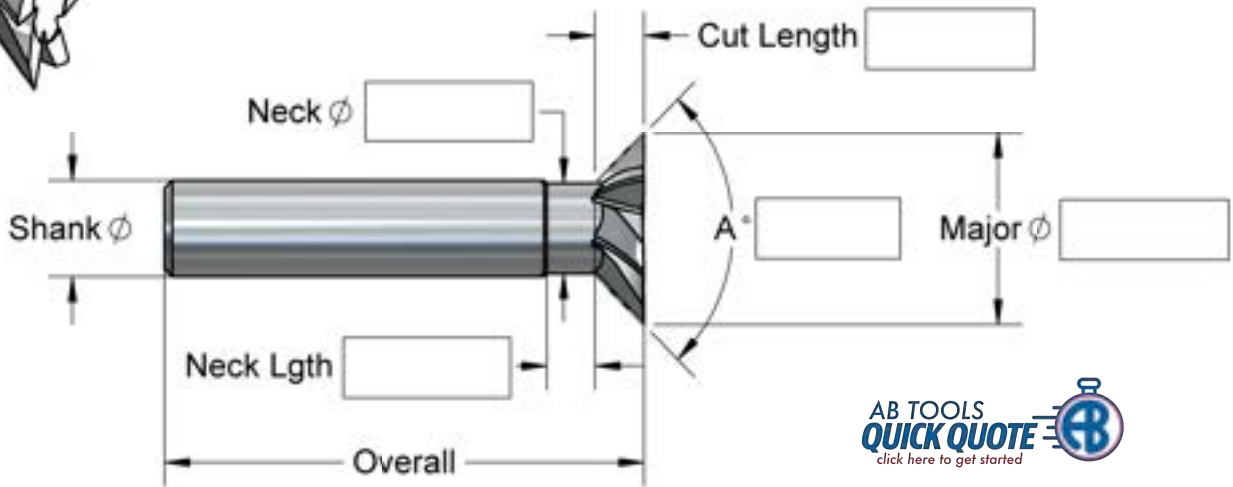

Add \$40. each for corner radius (R.060 Max)

Ø1/2" shank x 2.5" Overall			Number	Major Ø	A°	Cut Length	Neck Ø	Neck Lgth	Flutes	Price	Altin
Ø1/2" shank x 2.5" Overall			DS75-60	.750	60	.313	.370	.250	6	\$215.	\$226.
Ø1/2" shank x 2.5" Overall			DS75-90	.750	90	.188	.360	.250	6	\$215.	\$226.
Ø1/2" shank x 2.5" Overall			DS75-120	.750	120	.120	.320	.370	6	\$215.	\$226.
Ø1/2" shank x 2.5" Overall			DS1-60	1.0	60	.435	.480	.250	6	\$230.	\$246.
Ø1/2" shank x 2.5" Overall			DS1-90	1.0	90	.255	.470	.250	6	\$230.	\$246.
Ø1/2" shank x 2.5" Overall			DS1-120	1.0	120	.160	.430	.370	6	\$230.	\$246.

Ø5/8" shank x 3" Overall			Number	Major Ø	A°	Cut Length	Neck Ø	Neck Lgth	Flutes	Price	Altin
Ø5/8" shank x 3" Overall			DS125-60	1.25	60	.500	.600	.250	8	\$285.	\$305.
Ø5/8" shank x 3" Overall			DS125-90	1.25	90	.360	.515	.250	8	\$285.	\$305.
Ø5/8" shank x 3" Overall			DS125-120	1.25	120	.225	.450	.370	8	\$285.	\$305.

Ø3/4" shank x 3.5" Overall			Number	Major Ø	A°	Cut Length	Neck Ø	Neck Lgth	Flutes	Price	Altin
Ø3/4" shank x 3.5" Overall			DS15-60	1.5	60	.625	.725	.250	8	\$340.	\$365.
Ø3/4" shank x 3.5" Overall			DS15-90	1.5	90	.440	.600	.250	8	\$340.	\$365.
Ø3/4" shank x 3.5" Overall			DS15-120	1.5	120	.285	.500	.370	8	\$340.	\$365.



A. B. TOOLS, INC.  
1051 Aviation Blvd.  
Lincoln, CA 95648-9312

Phone 916 408-2442  
FAX 916 993-3949

www.abtoolsinc.com  
E-Mail: mail@abtoolsinc.com

# Carbide Tipped Dovetail Cutters

## Specials in 4-6 Working Days

Machining what part material, please? \_\_\_\_\_



Available without flat upon request

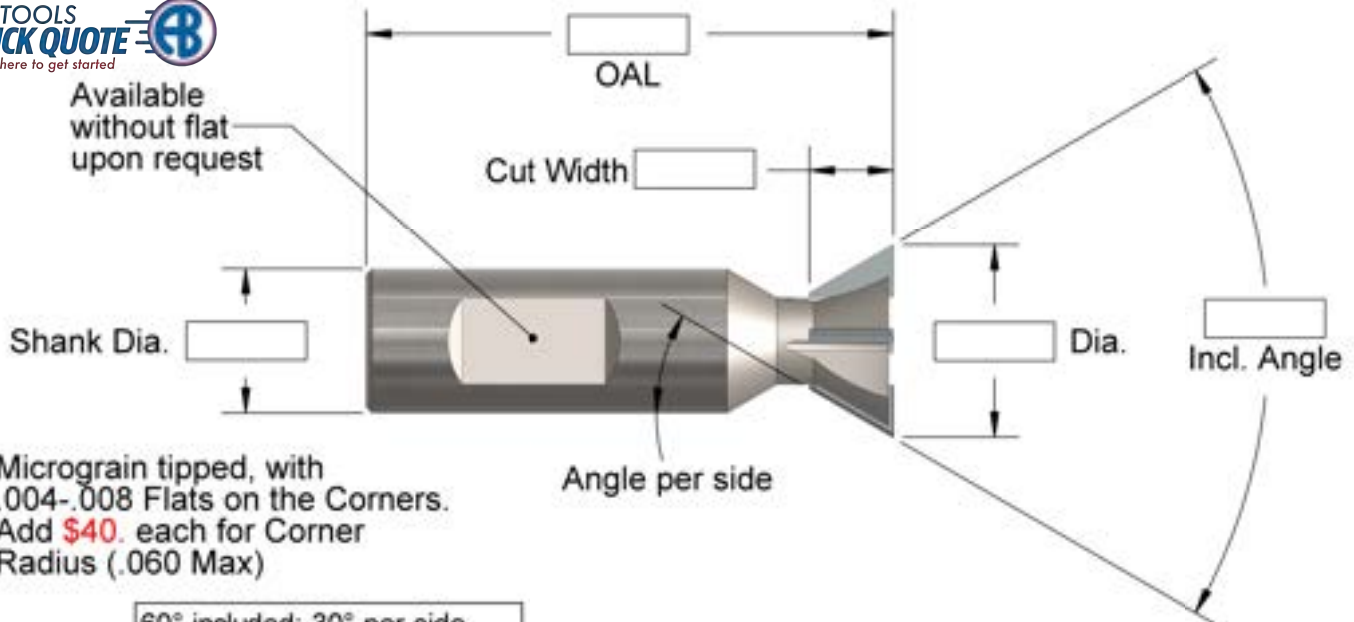

Micrograin tipped, with .004-.008 Flats on the Corners. Add \$40. each for Corner Radius (.060 Max)

60° included; 30° per side							Price	
Number	Incl. Angle	Dia.	Cut Width	Shank Dia.	OAL	N	No-Coat	AlTiN
D60-.75	60°	3/4	5/16	3/4	2-3/4	3	\$180.	\$192.
D60-1.0	60°	1.00	7/16	3/4	2-3/4	4	\$190.	\$207.
D60-1.25	60°	1.25	1/2	3/4	3	5	\$200.	\$221.
D60-1.38	60°	1.38	1/2	3/4	3	6	\$210.	\$234.
D60-1.5	60°	1.50	5/8	3/4	3-1/2	6	\$265.	\$289.
D60-2.0	60°	2.00	7/8	1.0	3-3/4	8	\$305.	\$406.
D60-2.5	60°	2.50	7/8	1.0	3-3/4	8	\$395.	\$512.

90° included; 45° per side							Price	
Number	Incl. Angle	Dia.	Cut Width	Shank Dia.	OAL	N	No-Coat	AlTiN
D90-.75	90°	3/4	3/16	1/2	2-1/4	3	\$185.	\$197.
D90-1.0	90°	1.00	1/4	1/2	2-1/2	5	\$195.	\$212.
D90-1.25	90°	1.25	5/16	5/8	2-3/4	5	\$255.	\$276.
D90-1.5	90°	1.50	7/16	3/4	3-1/4	6	\$325.	\$351.
D90-1.75	90°	1.75	1/2	3/4	3-3/4	6	\$375.	\$407.
D90-2.0	90°	2.00	9/16	1.0	4	6	\$410.	\$511.
D90-2.5	90°	2.50	3/4	1.0	4-1/2	6	\$475.	\$592.

N = number of flutes



A. B. TOOLS, INC.  
1051 Aviation Blvd.  
Lincoln, CA 95648-9312

Phone 916 408-2442  
FAX 916 993-3949

www.abtoolsinc.com  
E-Mail: mail@abtoolsinc.com

# The Dexi-Dovetail Short Inserts

.390 with Di60 inserts  
Cut Depths 60°

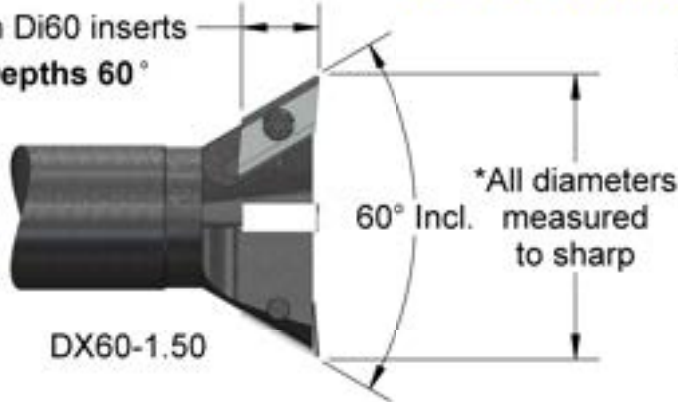

.447 with Di60 inserts  
Cut Depths 30°

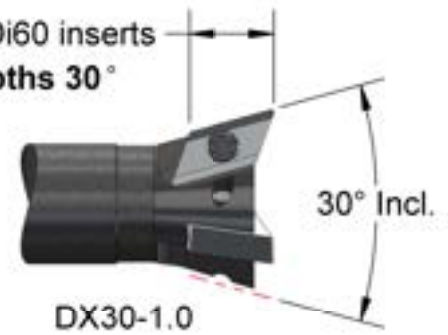

Cutter Number	*Dia.	Cut Depth	Incl. Angle	Shank & Overall	Flutes	Price
DX10-1.25	1-1/4	.440	10°	3/4 X 3.5	4	<b>\$225.</b>
DX20-1.0	1.0	.430	20°	5/8 X 3.5	3	<b>\$205.</b>
DX20-1.25	1-1/4	.430	20°	3/4 X 3.5	3	<b>\$215.</b>
DX20-1.50	1-1/2	.430	20°	3/4 X 3.5	4	<b>\$235.</b>
DX30-1.0	1.0	.420	30°	5/8 X 3.5	3	<b>\$215.</b>
DX30-1.25	1-1/4	.420	30°	3/4 X 3.5	3	<b>\$215.</b>
DX40-1.25	1-1/4	.410	40°	3/4 X 3.5	3	<b>\$215.</b>
DX45-1.25	1-1/4	.405	45°	3/4 X 3.5	3	<b>\$215.</b>
DX50-1.25	1-1/4	.400	50°	3/4 X 3.5	3	<b>\$215.</b>
DX60-1.25	1-1/4	.390	60°	1/2 X 3.0	3	<b>\$215.</b>
DX60-1.38	1-3/8	.390	60°	5/8 X 3.5	3	<b>\$225.</b>
DX60-1.50	1-1/2	.390	60°	3/4 X 3.5	4	<b>\$250.</b>
DX60-8	1-1/4	.390	60°	1-1/4 X 8.0	3	<b>\$300.</b>

Short Insert	Insert Number	Radius	Price	
			No-Coat	AlTiN
	Di60-0078	.0078		
	Di60-1	.015	<b>\$12.25</b>	<b>\$15.00</b>
	Di60-2	.030		

Screw & Key	Number	Price
	DX-3MM	<b>\$2.50</b>
	T8	<b>\$6.00</b>

*We use all these cutters in production, milling (38Rc) 4340 at 1100 to 1800 RPM and .001 to .002 IPT.*



A. B. TOOLS, INC.  
1051 Aviation Blvd.  
Lincoln, CA 95648-9312

Phone 916 408-2442  
FAX 916 993-3949

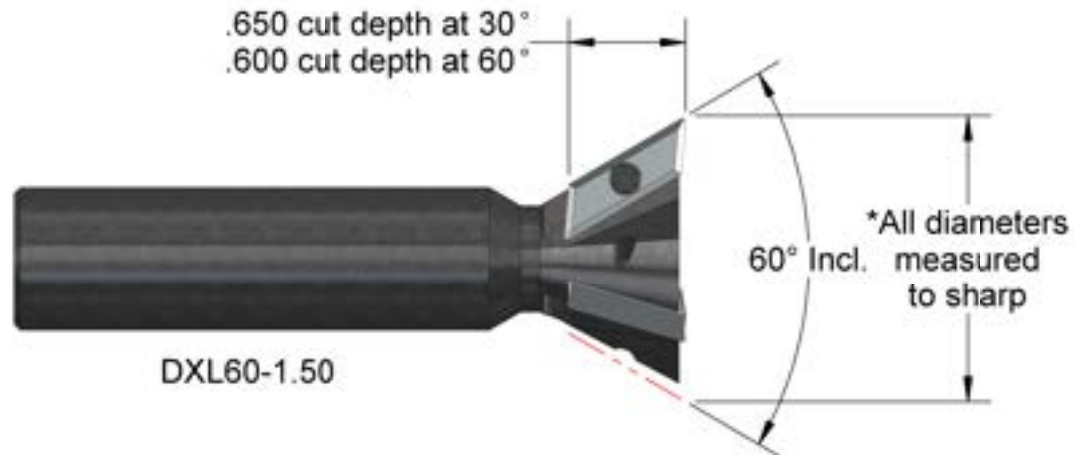

www.abtoolsinc.com  
E-Mail: mail@abtoolsinc.com

# The Dexi-Dovetail Long Inserts



Number	*Dia.	Cut Depth	Incl. Angle	Shank & Overall	Flutes	Price
DXL20-1.25	1-1/4	.650	20°	3/4 X 3.5	3	\$265.
DXL30-1.25	1-1/4	.640	30°	3/4 X 3.5	3	\$265.
DXL30-1.312	1-5/16	.640	30°	3/4 X 3.5	3	\$270.
DXL30-1.37	1-3/8	.640	30°	3/4 X 3.5	3	\$275.
DXL30-2.0	2.0	.640	30°	1 X 3.88	5	\$395.
DXL40-1.50	1-1/2	.650	40°	3/4 X 3.5	3	\$285.
DXL50-1.50	1-1/2	.620	50°	3/4 X 3.5	3	\$285.
DXL50-2.0	2.0	.620	50°	1 X 4.0	4	\$375.
DXL60-1.50	1-1/2	.600	60°	3/4 X 3.5	3	\$285.
DXL60-1.62	1-5/8	.600	60°	3/4 X 3.5	3	\$300.
DXL60-2.0	2.0	.600	60°	1 X 3.88	4	\$395.
DXL60-3.0	3.0	.600	60°	1-1/4 X 4.5	6	\$575.

Long Insert 	Insert Number	Radius	Price	
			No-Coat	AlTiN
	Di60L-1	.015		
	Di60L-2	.030	\$13.75	\$16.25
	Di60L-3	.046		

Screw & Key	Number	Price
	DX-3MM	\$2.50
	T8	\$6.00

*We use all these cutters in production, milling (38Rc) 4340 at 1100 to 1800 RPM and .001 to .002 IPT.*



A. B. TOOLS, INC.  
1051 Aviation Blvd.  
Lincoln, CA 95648-9312

Phone 916 408-2442  
FAX 916 993-3949

www.abtoolsinc.com  
E-Mail: mail@abtoolsinc.com



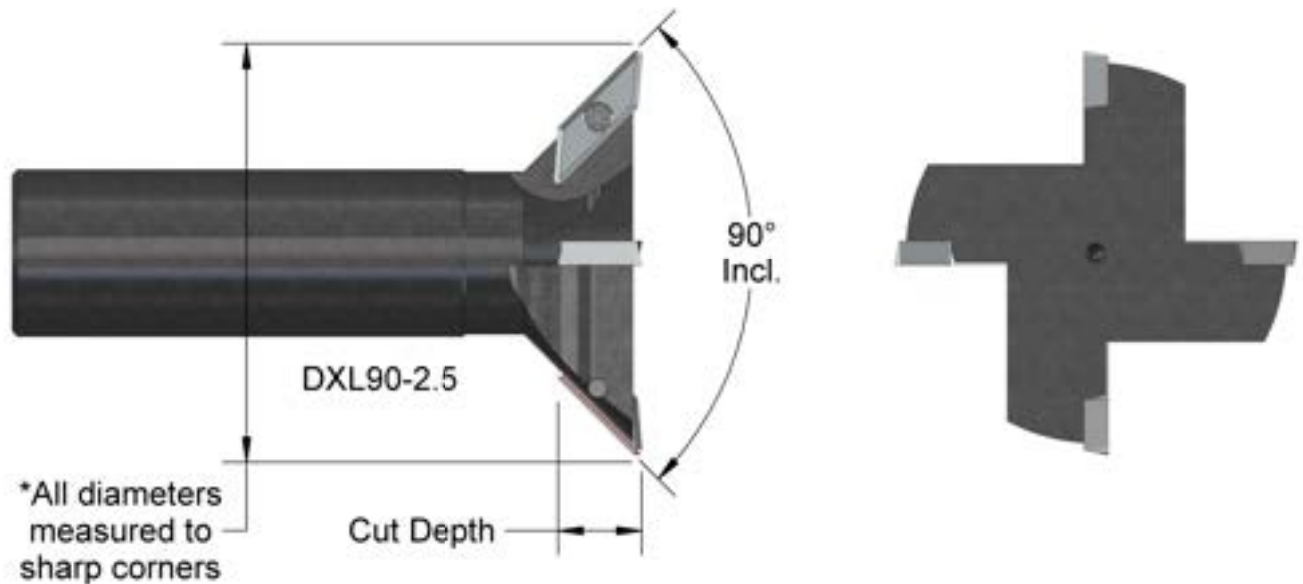

# 70° to 90° Dexi-Dovetail Original Width Inserts



Number	*Dia.	Cut Depth	Incl. Angle	Shank & OAL	Flutes	Price
DXL70-1.75	1.750	.560	70°	3/4 X 3.75	3	\$365.
DXL70-2.0	2.000	.560	70°	1 X 3.75	3	\$375.
DXL75-2.0	2.000	.550	75°	1 X 3.75	3	\$375.
DXL80-2.0	2.000	.530	80°	1 X 3.75	3	\$375.
DXL90-2.0	2.000	.490	90°	3/4 X 3.75	3	\$375.
DXL90-2.5	2.500	.490	90°	1 X 3.75	4	\$475.
DXL90-3.0	3.000	.490	90°	1 X 3.75	5	\$540.

Original Long Insert 	Insert Number	Radius	Price	
			No-Coat	AlTiN
	Di90L-1	.015		
	Di90L-2	.030	\$13.75	\$16.25
	Di90L-3	.046		

Screw & Key	Number	Price
	DX-3MM	\$2.50
	T8	\$6.00



A. B. TOOLS, INC.  
1051 Aviation Blvd.  
Lincoln, CA 95648-9312

Phone 916 408-2442  
FAX 916 993-3949

www.abtoolsinc.com  
E-Mail: mail@abtoolsinc.com

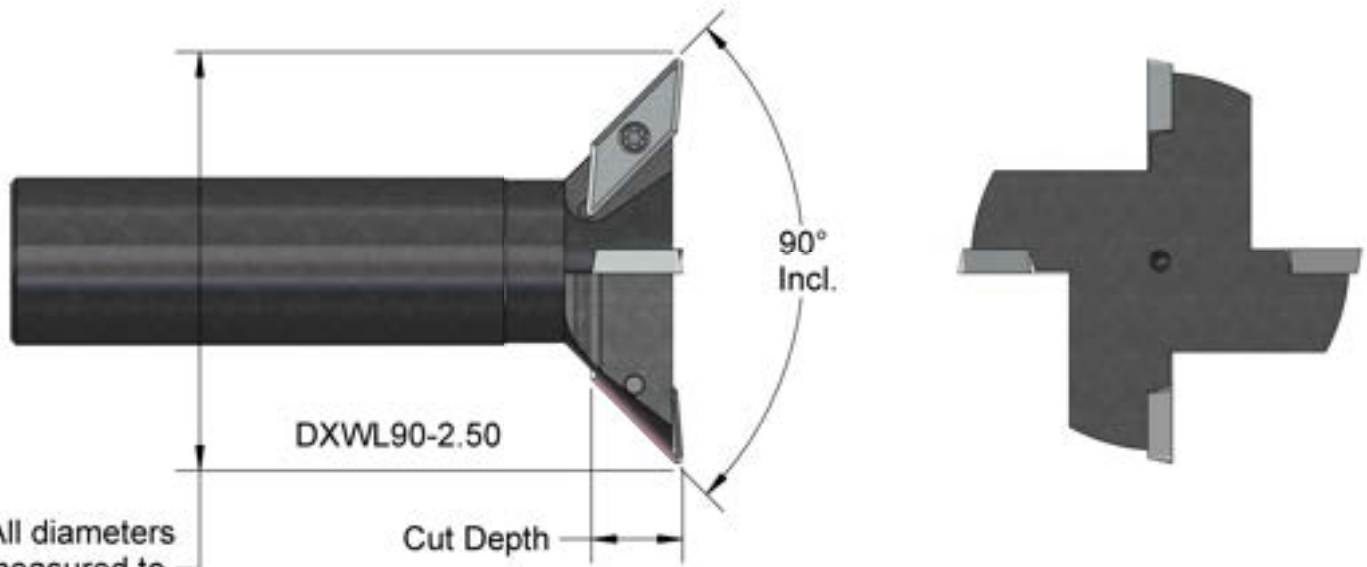

# 70° to 90° Dexi-Dovetails wider, stronger inserts



\*All diameters measured to sharp corners

Number	*Dia.	Cut Depth	Incl. Angle	Shank & OAL	Flutes	Price
DXWL70-2.0	2.000	.560	70°	1 X 4	3	\$385.
DXWL80-2.25	2.250	.530	80°	1 X 4	3	\$425.
DXWL90-2.25	2.250	.490	90°	1 X 4	3	\$425.
DXWL90-2.50	2.500	.490	90°	1 X 4	4	\$440.
DXWL90-3.0	3.000	.490	90°	1 X 4	4	\$550.

Wide Insert				
	Insert Number	Radius	Price	
			No-Coat	AlTiN
	Di90WL-1	.015	\$15.00	\$17.50
Di90WL-2	.030			

Screw & Key	Number	Price
	DX-3MM	\$2.50
	T8	\$6.00



A. B. TOOLS, INC.  
1051 Aviation Blvd.  
Lincoln, CA 95648-9312

Phone 916 408-2442  
FAX 916 993-3949

www.abtoolsinc.com  
E-Mail: mail@abtoolsinc.com

**NEW !!!**

# All Purpose Indexable End Mills

**NEW !!!**





APM750-75 Shown Full Size

Number	Cut Dia.	Shank Dia.	No. of Flutes	Insert size	Price
APM625-5	.625	1/2"	2	APi11	<b>\$210.</b>
APM625-75	.625	3/4"	2	APi11	<b>\$210.</b>
APM750-5	.750	1/2"	3	APi11	<b>\$235.</b>
APM750-75	.750	3/4"	3	APi11	<b>\$235.</b>
APM100-75	1.000	3/4"	2	APi16	<b>\$260.</b>
APM100-1	1.000	1"	2	APi16	<b>\$260.</b>
APM125-75	1.250	3/4"	3	APi16	<b>\$310.</b>
APM125-1	1.250	1"	3	APi16	<b>\$310.</b>

APi11 Inserts			
	Number	Radius	Price
	APi11-031G	0.031	<b>\$9.</b>
	APi11-031N	0.031	<b>\$9.</b>

G = General Purpose/Steels N = Non-Ferrous/Aluminum

APi16 Inserts			
	Number	Radius	Price
	APi16-063G	0.063	<b>\$13.75</b>
	APi16-094G	0.094	<b>\$13.75</b>
	APi16-125G	0.125	<b>\$13.75</b>
	APi16-037N	0.037	<b>\$13.75</b>

Hardware	
	
Insert Screw	Wrench
APM11 Insert Size	
2.5mm-AP	T8
<b>\$4.25</b>	<b>\$6.</b>
APM16 Insert Size	
4mm-AP	T15
<b>\$5.</b>	<b>\$7.50</b>



A. B. TOOLS, INC.  
 1051 Aviation Blvd.  
 Lincoln, CA 95648-9312

Phone 916 408-2442  
 FAX 916 993-3949

www.abtoolsinc.com  
 E-Mail: mail@abtoolsinc.com

# NEW !!! All Purpose Indexable Chamfer Cutters NEW !!!

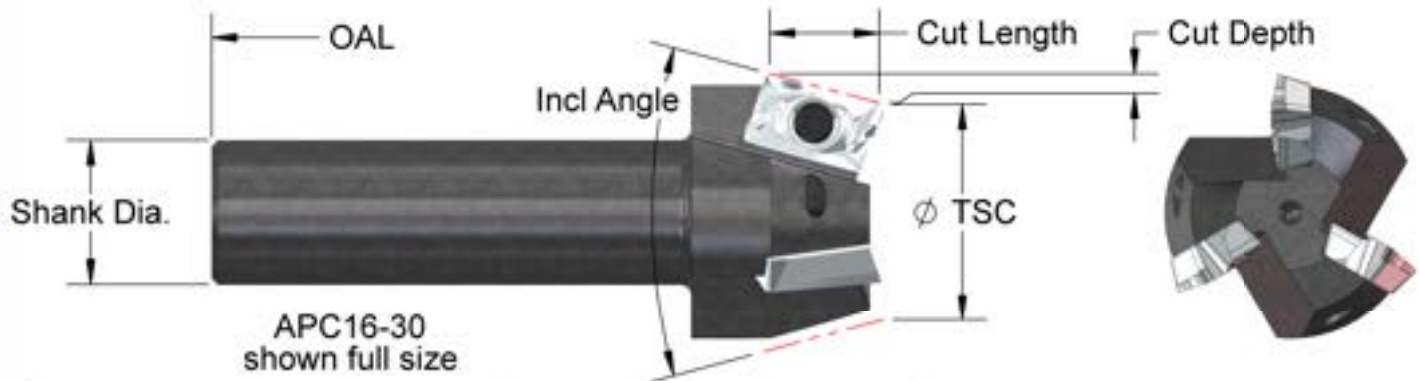

Number	∅ TSC	Incl Angle	Cut Length	Cut Depth	Shank Dia.	OAL	No. of Flutes	Insert Size	Price
APC11-30	3/4	30°	.325	.080	1/2	2-1/2	3	APi11	\$250.
APC11-60	3/4	60°	.290	.165	1/2	2-1/2	3	APi11	\$250.
APC11-82	3/4	82°	.250	.220	1/2	2-1/2	3	APi11	\$250.
APC11-90	3/4	90°	.235	.235	3/4	3-1/2	3	APi11	\$295.
APC11-100	3/4	100°	.210	.260	3/4	3-1/2	3	APi11	\$295.
APC11-120	3/4	120°	.160	.290	3/4	3-1/2	3	APi11	\$295.
APC11-150	3/4	150°	.080	.325	3/4	3-1/2	3	APi11	\$295.
APC16-30	1.0	30°	.540	.140	3/4	3-1/2	3	APi16	\$415.
APC16-60	1.0	60°	.480	.285	3/4	3-1/2	3	APi16	\$415.
APC16-82	1.0	82°	.415	.370	3/4	3-1/2	3	APi16	\$415.
APC16-90	1.0	90°	.390	.400	3/4	3-1/2	3	APi16	\$415.
APC16-100	1.0	100°	.350	.430	3/4	3-1/2	3	APi16	\$415.
APC16-120	1.0	120°	.270	.490	3/4	3-1/2	3	APi16	\$450.
APC16-150	1.0	150°	.125	.545	3/4	3-1/2	3	APi16	\$450.

### APi11 Inserts

	Number	Radius	Price
	APi11-031G	0.031	\$9.
	APi11-031N	0.031	\$9.

G = General Purpose/Steels N = Non-Ferrous/Aluminum

### APi16 Inserts

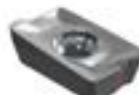
	Number	Radius	Price
	APi16-063G	0.063	\$13.75
	APi16-094G	0.094	\$13.75
	APi16-125G	0.125	\$13.75
	APi16-037N	0.037	\$13.75

### Hardware

	
Insert Screw	Wrench
APM11 Insert Size	
2.5mm-AP	T8
\$4.25	\$6.
APM16 Insert Size	
4mm-AP	T15
\$5.	\$7.50



A. B. TOOLS, INC.  
1051 Aviation Blvd.  
Lincoln, CA 95648-9312

Phone 916 408-2442  
FAX 916 993-3949

www.abtoolsinc.com  
E-Mail: mail@abtoolsinc.com

# NEW !!! All Purpose Indexable Back Chamfer Cutters NEW !!!

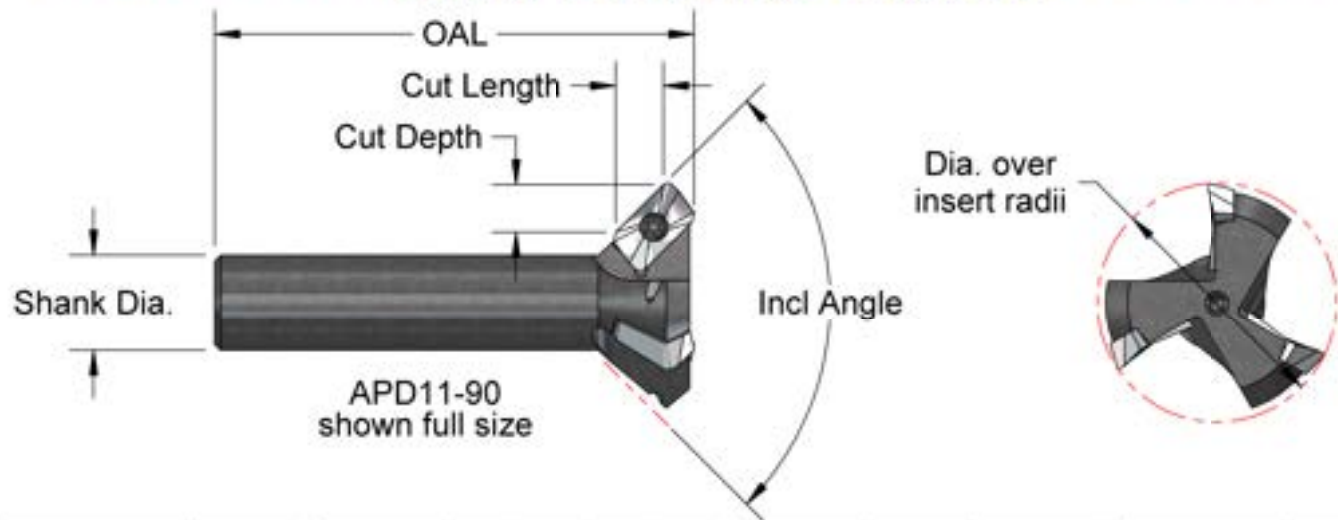

Number	Dia.	Incl Angle	Cut Depth	Cut Length	Shank Dia.	OAL	No. of Flutes	Insert Size	Price
APD11-90	1.250	90	.235	.235	1/2	2-1/2	3	APi11	\$240.
APD11-100	1.375	100	.255	.210	1/2	2-1/2	3	APi11	\$250.
APD11-120	1.375	120	.290	.160	1/2	2-1/2	3	APi11	\$250.
APD11-140	1.375	140	.315	.110	1/2	2-1/2	3	APi11	\$250.
APD11-150	1.375	150	.325	.080	1/2	2-1/2	3	APi11	\$250.
APD16-90	2.0	90	.390	.400	3/4	3-1/2	3	APi16	\$415.
APD16-100	2.0	100	.420	.350	3/4	3-1/2	3	APi16	\$415.
APD16-120	2.0	120	.480	.280	3/4	3-1/2	3	APi16	\$415.
APD16-140	2.0	140	.530	.190	3/4	3-1/2	3	APi16	\$415.
APD16-150	2.0	150	.540	.140	3/4	3-1/2	3	APi16	\$415.

APi11 Inserts			
	Number	Radius	Price
	APi11-031G	0.031	\$9.
	APi11-031N	0.031	\$9.

G = General Purpose/Steels N = Non-Ferrous/Aluminum

APi16 Inserts			
	Number	Radius	Price
	APi16-063G	0.063	\$13.75
	APi16-094G	0.094	\$13.75
	APi16-125G	0.125	\$13.75
	APi16-037N	0.037	\$13.75

Hardware	
	
Insert Screw	Wrench
APM11 Insert Size	
2.5mm-AP	T8
\$4.25	\$6.
APM16 Insert Size	
4mm-AP	T15
\$5.	\$7.50



A. B. TOOLS, INC.  
1051 Aviation Blvd.  
Lincoln, CA 95648-9312

Phone 916 408-2442  
FAX 916 993-3949

www.abtoolsinc.com  
E-Mail: mail@abtoolsinc.com

# Spot-Dex Tools (for all part materials)

SD-90T3 shown here

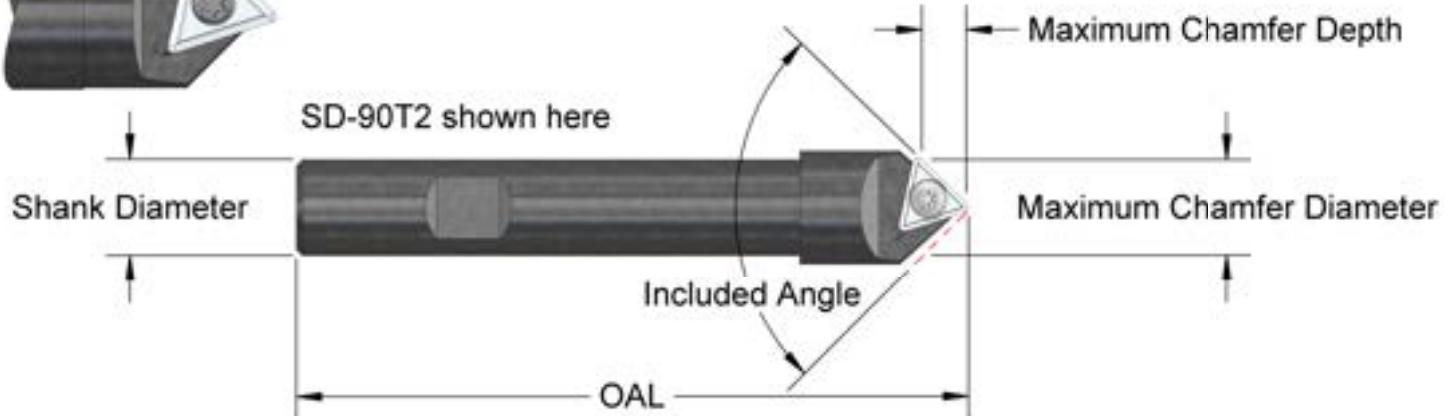

SD-60D3 shown here



SD-60D2 shown here



\*These all use Industry Standard inserts with secondary clearance facets ground to avoid dragging on the small cut diameters.\*

We've spot drilled to .190 depth with the SD-60D2 in mild steel at 4000 RPM and 1 IPM, and milled grooves in X-Y at 10 IPM.

Number	Included Angle	Max Chamfer Dia.	Max Chamfer Depth	*Insert No. (modified)	Screw Size	Shank and OAL	Price including Wrench & Screw
SD-60D2	60°	.310	.240	DPMT-21.51	2.5MM	1/2 X 3.5	\$190.
SD-60D3	60°	.480	.380	DPMT-32.52	4MM		\$210.
SD-70D2	70°	.350	.230	DPMT-21.51	2.5MM		\$190.
SD-70D3	70°	.530	.340	DPMT-32.52	4MM		\$210.
SD-82T2	82°	.530	.290	TPMT2-2	4-40	1/2 X 3.5	\$190.
SD-82T3	82°	.770	.410	TPMT322	4MM	3/4 X 5.0	\$210.
SD-90T2	90°	.570	.270	TPMT2-2	4-40	1/2 X 3.5	\$190.
SD-90T3	90°	.820	.390	TPMT322	4MM	3/4 X 5.0	\$210.
SD-100T2	100°	.610	.240	TPMT2-2	4-40	1/2 X 3.5	\$190.
SD-100T3	100°	.890	.350	TPMT322	4MM	3/4 X 5.0	\$210.
SD-120T2	120°	.680	.190	TPMT2-2	4-40	1/2 X 3.5	\$190.
SD-120T3	120°	.990	.270	TPMT322	4MM	3/4 X 5.0	\$210.

Insert Number	R. Size	Price
DPMT-21.51	.015	\$17.50
TPMT2-2	.031	\$15.00
DPMT-32.52	.031	\$19.00
TPMT322	.031	\$17.50

Screw	Price
2.5 MM	\$4.25
4-40	\$5.00
4 MM	\$5.00
4 MM	\$5.00

Wrench	Price
Torxit-7	\$6.00
Torxit-7	\$6.00
Torxit-15	\$7.50
Torxit-15	\$7.50



A. B. TOOLS, INC.  
1051 Aviation Blvd.  
Lincoln, CA 95648-9312

Phone 916 408-2442  
FAX 916 993-3949

www.abtoolsinc.com  
E-Mail: mail@abtoolsinc.com

# The Single Flute Chamfer Hogs



This cutter was developed in 1982 for spot drilling and chamfer milling small slots in non-ferrous part materials. If used prior to drilling in non-ferrous materials it performs well. If used as a countersink after the hole is drilled it is chatter prone.

It is not for use as a rotating cutter in ferrous materials since the (25°) relief angle is too weak. However, in the more rigid lathe environment it can be used successfully to spot drill holes in ferrous materials. We spot drill our Accu-Holds (4340) in CNC lathes at 900 RPM and .0005 IPR, with tool life of 200 holes per insert corner.

**It should never be used in a drill press.**

All five cutters have 3/4 shanks and are 5" overall.

All Single Flute Chamfer-Hogs, including inserts, are **\$205.** ea.

Number	Included Angle	Maximum Chamfer Diameter	Insert	Clamp	Insert Prices	
CHA90-1	90°	.800	TFG32-90	CL-4	TFG32-90	<b>\$13.75</b>
CHA82-1	82°	.730	TFG32-90	CL-4	TFG32-90T (TiN Coated)	<b>\$16.00</b>
CHA100-1	100°	.940	TFG32-90	CL-4	TD6P-120	<b>\$15.00</b>
CHA120-1	120°	1.00	TD6P-120	5-40		
CHA60-1*	60°	1.00	TFG32-90	CL-4		

\* Note: CHA60-1 is **not** center cut; it has .200 end cut diameter.

The CL-4 Clamps are **\$17.50** each, includes screw.

The 10-32 Socket Head Cap Screw is Industry Standard.

TFG-322 and TD-6P are Industry Standard Inserts modified with a secondary facet near the point to prevent "heeling".



A. B. TOOLS, INC.  
1051 Aviation Blvd.  
Lincoln, CA 95648-9312

Phone 916 408-2442  
FAX 916 993-3949

www.abtoolsinc.com  
E-Mail: mail@abtoolsinc.com

# Positive Rake Chamfer-Hogs

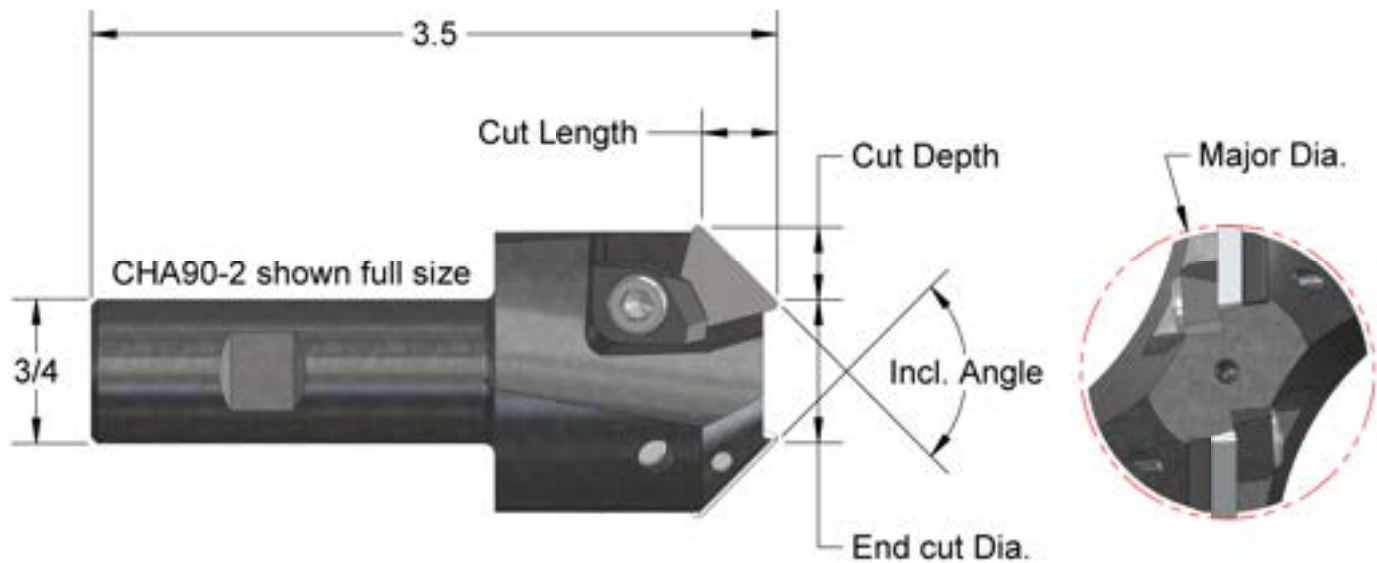

All Positive Chamfer-Hogs use  
Insert TPU322 and Shim SM41  
For Ferrous or Non-Ferrous

Number	Included Angle	No. of Flutes	End Dia.	Major Dia.	Cut Lgth.	Cut Depth	Clamp No.	Price Incl. Inserts
CHA90-2	90°	2	3/4	1.5	.37	.37	CL2	\$310.
CHA120-2	120°	2	5/8	1.6	.19	.42	CL2	\$310.
CHA60-3P	60°	3	1.1	1.6	.42	.19	CL5	\$410.
CHA150-2	150°	2	.47	1.56	.14	.52	CL2	\$310.

Insert	Price	Clamps	Price	Shims	Price	Screws at no charge with each purchase of Clamps & Shims. Ind. Standard 10-32 & 1/4-20 Socket Head, and 5-40 Flat Head.
TPU322 C5	\$12.50.	CL2	\$17.50.	SM41 Modified	\$17.50.	
		CL5	\$22.50.			



A. B. TOOLS, INC.  
1051 Aviation Blvd.  
Lincoln, CA 95648-9312

Phone 916 408-2442  
FAX 916 993-3949

www.abtoolsinc.com  
E-Mail: mail@abtoolsinc.com



# Negative Rake Chamfer-Hogs (Ferrous Only)

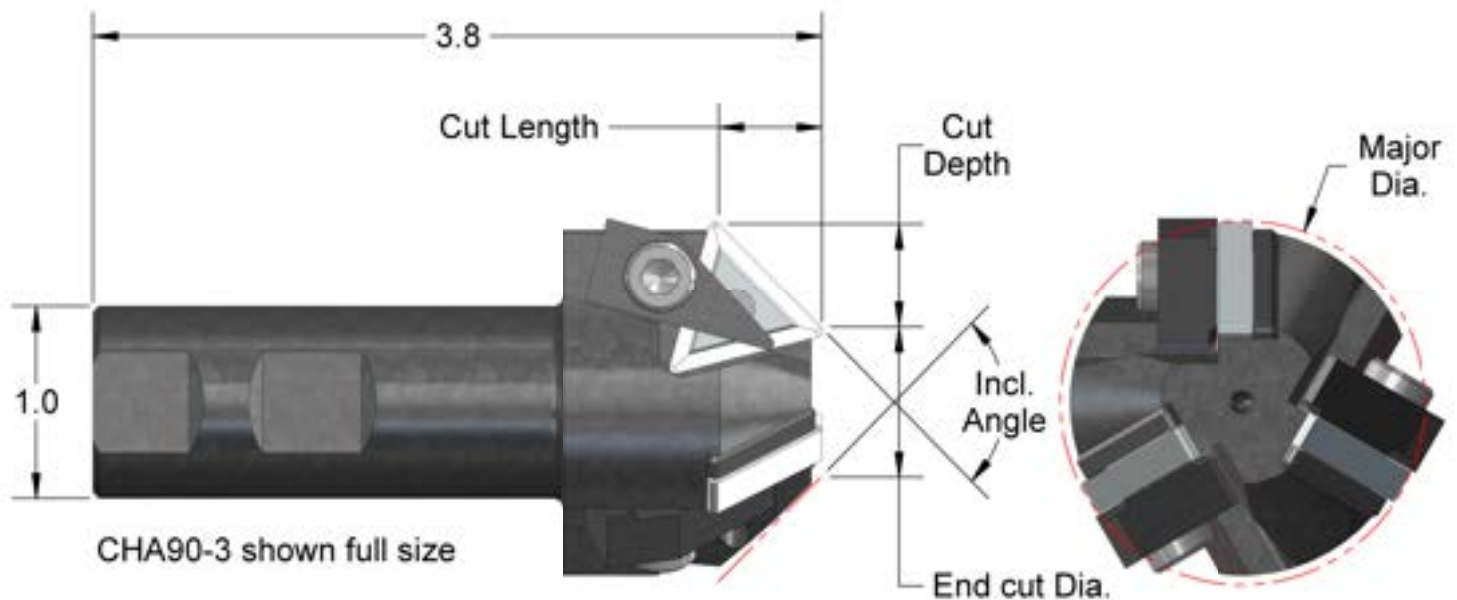

Number	Included Angle	No. of Flutes	End Dia.	Major Dia.	Cut Lgth.	Cut Depth	Clamp No.	Price Incl. Inserts
CHA30-3	30°	3	1.75	2.16	.73	.25	CL5	\$450.
CHA60-3N	60°	3	1.40	1.60	.65	.45	CL5	\$450.
CHA70-3	70°	3	1.25	2.14	.62	.44	CL5	\$450.
CHA82-3	82°	3	1.0	2.02	.57	.50	CL5	\$450.
CHA90-3	90°	3	.75	1.90	.52	.52	CL5	\$450.
CHA90-4	90°	4	1.76	2.85	.52	.52	CL5	\$515.
CHA100-3	100°	3	.82	1.99	.49	.58	CL5	\$450.
CHA110-3	110°	3	.75	2.02	.43	.62	CL5	\$450.
CHA120-3	120°	3	.75	2.10	.29	.62	CL5	\$450.
CHA130-3	130°	3	.77	2.16	.32	.67	CL5	\$450.
CHA140-3	140°	3	.75	2.20	.25	.70	CL5	\$450.

All Negative Rake Chamfer-Hogs use the below insert, clamp, and shim

Insert	Price	Clamp	Price	Shim	Price	Screws at no charge with each purchase of Clamps & Shims. Ind. Standard 10-32 & 1/4-20 Socket Head and 5-40 Flat Head.
TNMG432 C5	\$16.	CL5	\$22.50.	SM26 Ind. Std.	\$12.	



A. B. TOOLS, INC.  
1051 Aviation Blvd.  
Lincoln, CA 95648-9312

Phone 916 408-2442  
FAX 916 993-3949

www.abtoolsinc.com  
E-Mail: mail@abtoolsinc.com

Are you tired of hand ground screw flats on your tool and cutter shanks?

Mill precise flats with our Weldon Flat Tools.

See page 49 for the USCTI Weldon Flat specifications

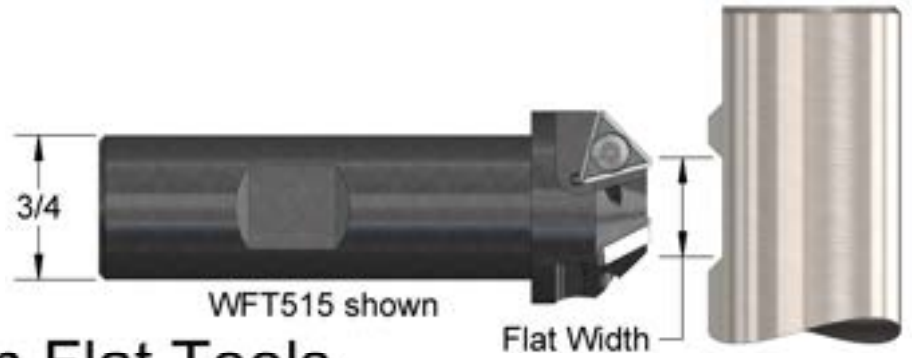

## Weldon Flat Tools

Number	Flat Width	For these Shank sizes	Number of Flutes	Price
WFT280	.280	.375	1	\$205.
WFT330	.330	.500	2	\$220.
WFT400	.400	.625	2	\$235.
WFT455	.455	.750 & .875	3	\$265.
WFT515	.515	1.0, 1.25, 1.5	3	\$285.
WFT700	.700	2.0	3	\$345.

We mill Weldon Flats with the WFT515 in 4340 alloy steel hardened to Rc 46 @ 1500 RPM and .002 IPT. These cutters will also mill the shanks on standard HSS end mills which are drawn to Rc 55.

Would you prefer linear flats for easy "Z" Axis adjustment?

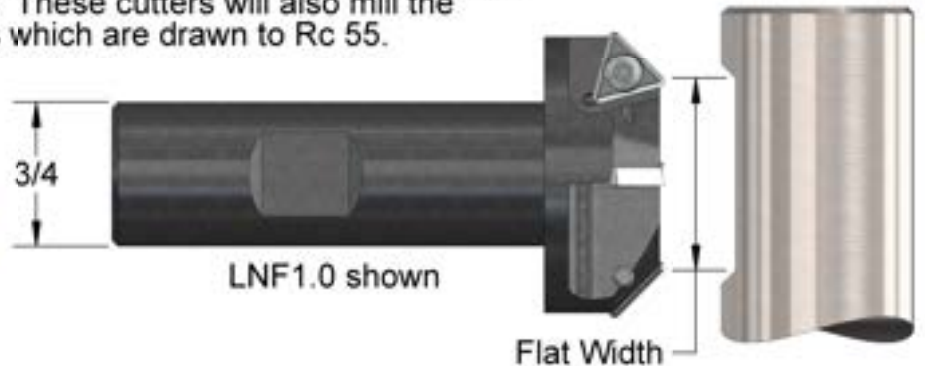

## Linear Flat Tools for any Shank size

Number	Flat Width	Number of Flutes	Price
LNF750	.750	4	\$350.
LNF1.0	1.000	4	\$375.
LNF1125	1.125	4	\$405.
LNF1250	1.250	5	\$450.

Insert	Price
TPMT2-2	\$15.00

Screw	Price
SR 14-505	\$4.50

Wrench	Price
Torxit-8	\$6.00



A. B. TOOLS, INC.  
1051 Aviation Blvd.  
Lincoln, CA 95648-9312

Phone 916 408-2442  
FAX 916 993-3949

www.abtoolsinc.com  
E-Mail: mail@abtoolsinc.com

# SAW ARBORS for Carbide or HSS Saws with key drives for 5/8 and larger arbors

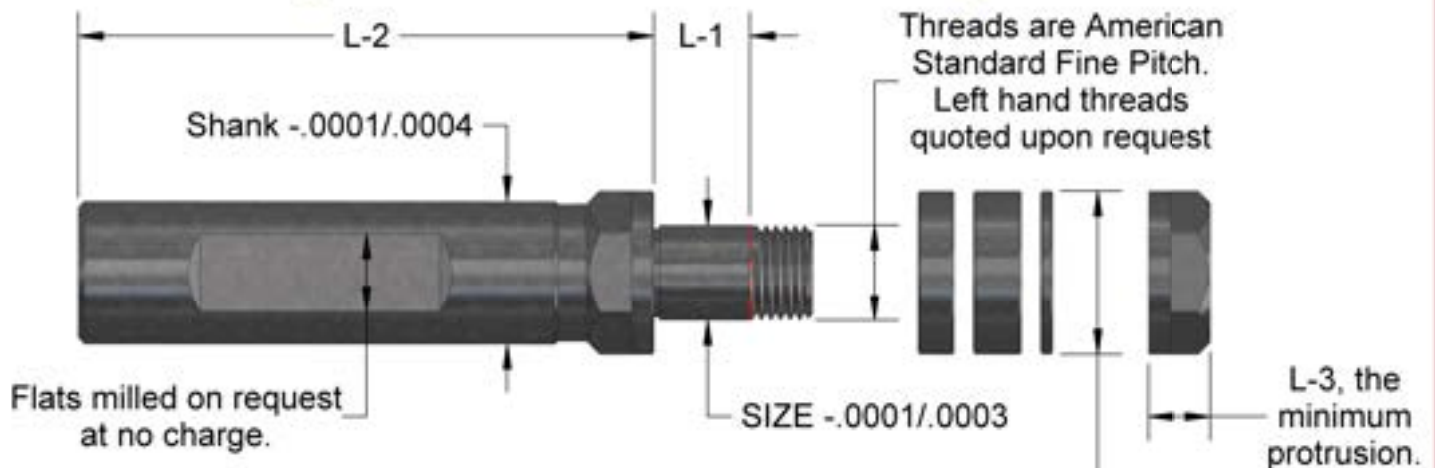

Flats milled on request at no charge.

Saws thinner than .050 must not rest on the shoulder. Either on one spacer or several.

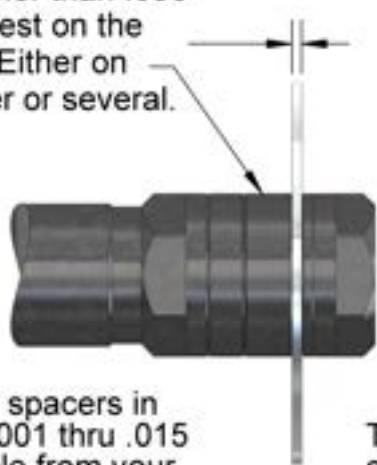

HUB  $\phi$ , the outside diameter of the Shoulder, Hex Nut and the spacers.

**Precise, for the thinnest saws.  
High Torque for Keyless saws.  
Rugged, with key drives.**

Hardened Alloy Steel, precision ground, Black Oxide coated.

Shim Style spacers in sets from .001 thru .015 are available from your Industrial Distributor.

The spacer assortments will accommodate most saws and spacers that will fit in the L-1 Length.  
\*Spacers ordered with Keyed Arbors will also have keyways.

Number	Size	Shank	L-1	L-2	L-3	Hub	Spacers with each Arbor	Price
SA250	.250	.500	.350	2.13	.250	.570	.0625 .125 .1875	\$225.
SA375	.375	.625	.375	2.40	.280	.710		\$245.
SA500	.500	.750	.500	3.00	.325	.855		\$265.
SA625	.625	.875	.500	3.15	.390	1.000	.0625 .1875 .250	\$330.
SA750	.750	1.00	.500	3.40	.440	1.215		\$345.
SA875	.875	1.00	.500	3.40	.440	1.434		\$360.
SA100	1.00	1.00	.500	3.50	.440	1.480		\$400.
SA125	1.25	1.25	.500	3.50	.440	2.000		\$475.

\*Sorry, unable to manufacture precise spacers thinner than .0625 in steel; suggest Robb-Jack's Solid Carbide spacers for thinner sizes.



A. B. TOOLS, INC.  
1051 Aviation Blvd.  
Lincoln, CA 95648-9312

Phone 916 408-2442  
FAX 916 993-3949

www.abtoolsinc.com  
E-Mail: mail@abtoolsinc.com

# The Accu-Hold

The MOST precise extension holder you have ever used.

Concentric within .0003; Hole size is plus .00015 and minus Zero.

Improves rigidity, concentricity, and coolant effectiveness.



Number	Hole size Ø	Decimal Equiv.	Shank size Ø	Overall Length	Screw Size	Price
ACH3/32	3/32	.0937	3/8	2-1/4	5-40	\$175.
ACH1/8	1/8	.125	3/8	3-1/4	8-32	\$185.
ACH1/8-6	1/8	.125	3/8	6	8-32	\$275.
ACH5/32	5/32	.1562	1/2	3-1/2	8-32	\$160.
ACH3/16	3/16	.1875	1/2	3-1/2	8-32	\$160.
ACH3/16-5	3/16	.1875	1/2	5	8-32	\$195.
ACH1/4	1/4	.250	5/8	4-1/4	10-32	\$170.
ACH1/4-6	1/4	.250	5/8	6	10-32	\$200.
ACH5/16	5/16	.3125	3/4	4-1/2	1/4-28	\$185.
ACH3/8	3/8	.375	3/4	4-1/2	5/16-24	\$195.
ACH3/8-6	3/8	.375	3/4	6	5/16-24	\$225.
ACH7/16	7/16	.4375	3/4	4-1/2	5/16-24	\$210.
ACH1/2*	1/2	.500	3/4	4-3/4	3/8-24	\$250.
ACH1/2-1	1/2	.500	1	4-3/4	3/8-24	\$275.
ACH1/2-6	1/2	.500	1	6	3/8-24	\$295.
ACH9/16	9/16	.5625	1	5-1/4	3/8-24	\$295.
ACH5/8	5/8	.625	1	5-1/2	3/8-24	\$295.
ACH3/4**	3/4	.750	1	5-1/4	7/16-20	\$340.
ACH3/4-1.25	3/4	.750	1-1/4	6	7/16-20	\$350.
ACH1.0**	1	1.000	1	5-1/2	7/16-20	\$475.

\*The ACH1/2 has a 1" Dia. x 1.5" long head.

\*\*The ACH3/4 and ACH1.0 have a 1-1/4" Dia. x 2-1/4" long head and the holes are only 2" deep.



A. B. TOOLS, INC.  
1051 Aviation Blvd.  
Lincoln, CA 95648-9312

Phone 916 408-2442  
FAX 916 993-3949

www.abtoolsinc.com  
E-Mail: mail@abtoolsinc.com

# The Metric Accu-Hold

The **MOST** precise extension holder you have ever used.

Concentric within .0003; Hole size is plus .00015 and minus Zero.

Improves rigidity, concentricity, and coolant effectiveness.



Number	Hole size Ø	Decimal Equiv.	Shank size Ø	Overall Length	Screw Size	Price
ACH3MM	3MM	.1181	3/8	3-1/4	8-32	\$185.
ACH4MM	4MM	.1575	1/2	3-1/2	8-32	\$170.
ACH5MM	5MM	.1968	1/2	3-1/2	8-32	\$170.
ACH6MM	6MM	.2362	5/8	4-1/4	10-32	\$175.
ACH7MM	7MM	.2756	5/8	4-1/4	10-32	\$225.
ACH8MM	8MM	.3149	3/4	4-1/2	1/4-28	\$185.
ACH9MM	9MM	.3543	3/4	4-1/2	5/16-24	\$240.
ACH10MM	10MM	.3937	3/4	4-1/2	5/16-24	\$215.
ACH11MM	11MM	.4331	3/4	4-1/2	5/16-24	\$260.
ACH12MM*	12MM	.4724	3/4	4-3/4	3/8-24	\$245.
ACH12MM-1	12MM	.4724	1	4-3/4	3/8-24	\$255.
ACH13MM	13MM	.5118	1	4-3/4	3/8-24	\$285.
ACH14MM	14MM	.5512	1	5-1/2	3/8-24	\$285.
ACH15MM	15MM	.5905	1	5-1/2	3/8-24	\$305.
ACH16MM	16MM	.6299	1	5-1/2	3/8-24	\$300.
ACH18MM**	18MM	.7086	1	5-1/4	7/16-20	\$315.
ACH20MM-1	20MM	.7874	1	6	7/16-20	\$340.
ACH20MM	20MM	.7874	1-1/4	6	7/16-20	\$340.
ACH25MM**	25MM	.9842	1	6-1/2	7/16-20	\$475.

\*The ACH12MM has a 1" Dia. x 1.5" long head.

\*\*The ACH18MM and ACH25MM have a 1-1/4" Dia. x 2-1/4" long head and the holes are only 2" deep.



A. B. TOOLS, INC.  
1051 Aviation Blvd.  
Lincoln, CA 95648-9312

Phone 916 408-2442  
FAX 916 993-3949

www.abtoolsinc.com  
E-Mail: mail@abtoolsinc.com

**NEW !!!**

# Accu-Hold MMH - All Metric

**NEW !!!**



The MOST precise extension holder you have ever used.

Concentric within .0003; Hole size is plus .00015 and minus Zero.

Improves rigidity, concentricity, and coolant effectiveness.

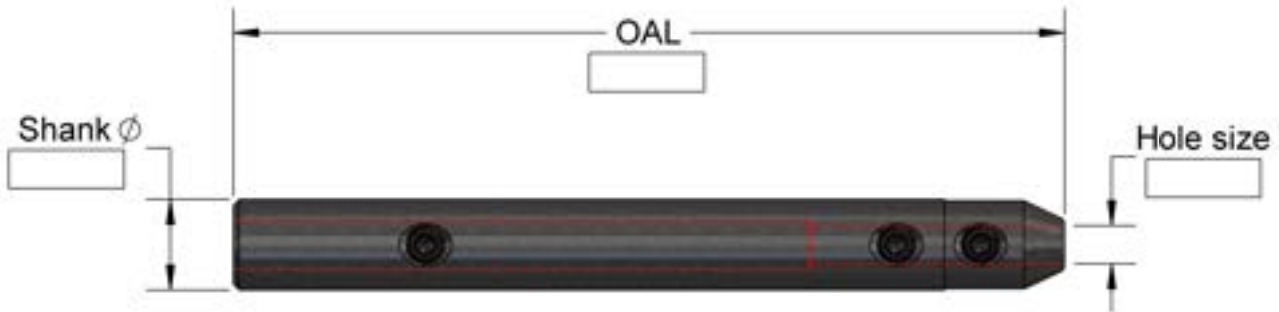

	Hole size $\phi$	Decimal size	Shank size $\phi$	Overall Length	Screw size	Price
MMH-03	3 mm	0.118	10 mm	82 mm	M2.5	\$220.
MMH-04	4 mm	0.157	12 mm	110 mm	M4	\$200.
MMH-05	5 mm	0.197	12 mm	110 mm	M5	\$200.
MMH-06	6 mm	0.236	16 mm	125 mm	M5	\$205.
MMH-08	8 mm	0.315	20 mm	135 mm	M6	\$225
MMH-10	10 mm	0.394	20 mm	135 mm	M8	\$275.
MMH-12	12 mm	0.472	25 mm	150 mm	M10	\$285.
MMH-16	16 mm	0.630	32 mm	150 mm	M12	\$315.
MMH-20	20 mm	0.787	32 mm	150 mm	M12	\$365.



A. B. TOOLS, INC.  
1051 Aviation Blvd.  
Lincoln, CA 95648-9312

Phone 916 408-2442  
FAX 916 993-3949

www.abtoolsinc.com  
E-Mail: mail@abtoolsinc.com

# The Aluma-Hogs

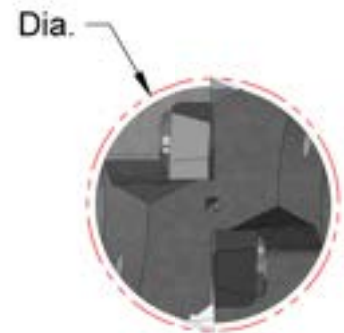

We started making ALUMA-HOGS in 1982. In 1997 we introduced the SHEAR-HOG; see back cover. With its high shear inserts, and no top clamps, the SHEAR-HOG outperforms the ALUMA-HOGS by 50% in Metal Removal rates. We will stock Aluma-Hogs, inserts, and parts as long as needed.

NUMBER	Dia.	Shank Dia.	OAL	Cut Length	Insert & Qty.	Clamp	Shim	Price Incl. Inserts
ALH1A	1.0	3/4	3.75	1/4	TEG2.522 (2)	CL1		\$215.
ALH1B	1.0	1.0	3.75	1/4	TEG2.522 (2)	CL1		\$215.
ALH1-5/16	1.312	3/4	3.75	1/2	TEG32MF (2)	CL2		\$265.
ALH1-7/8A	1.875	3/4	3.87	3/4	TEG42MF (2)	CL3		\$285.
ALH1-7/8B	1.875	1.0	4.12	3/4	TEG42MF (2)	CL3		\$285.
ALH2	2.0	1.0	4.12	3/4	TEG42MF (2)	CL3		\$325.
ALH3S	3.0	1.0	4.12	3/4	TEG42MF (3)	CL3	SM37	\$410.
ALH4S	4.0	1.0	4.25	3/4	TEG42MF (4)	CL3	SM37	\$535.

Inserts/Hardware	Relief Angle	Price
TEG2.522 (.031 R)	20°	\$12.50
TEG2.52MF (Mill Flat)	20°	\$14.00
TFG322 (.031 R)	25°	\$12.50
TFG32MF (Mill Flat)	25°	\$14.00
TEG422 (.031 R)	20°	\$14.75
TEG42MF (Mill Flat)	20°	\$17.00
CL1 or CL2 Clamp		\$16.50
CL3 Clamp		\$21.50
SM37 Shim, Modified		\$16.50

*Suggested Starting Data:*  
 Non-Ferrous ONLY  
 500/2,000 SFM; .002/.010 IPT  
 10,000 max RPM

See back cover, inside back cover and page 50 for information on the SHEAR-HOG, which will rough mill Aluminum at 6 CIM per HP.

Screws included with any Clamp/Shim orders.



A. B. TOOLS, INC.  
 1051 Aviation Blvd.  
 Lincoln, CA 95648-9312

Phone 916 408-2442  
 FAX 916 993-3949

www.abtoolsinc.com  
 E-Mail: mail@abtoolsinc.com

# Aluminum Milling Tests

**Faster CIM metal removal rates in aluminum depend more on IPM feed rates, horsepower and the cutter geometry than RPM.**

You'll get higher CIM with smaller cutters, (assuming you're rough milling with cutters about 1-1/4" diameter and larger). On tests with full diameter cuts, the 1-1/4" diameter cutter gets 42 CIM and the 2" diameter cutter gets 37 CIM.

You'll get higher CIM with a cut width that is about 3/4 of the cutter diameter than with a full diameter cut width, (a long accepted machinist's rule).

Compare tests below

You can get greater CIM with fewer flutes, plus reduced insert costs; see Test 3.

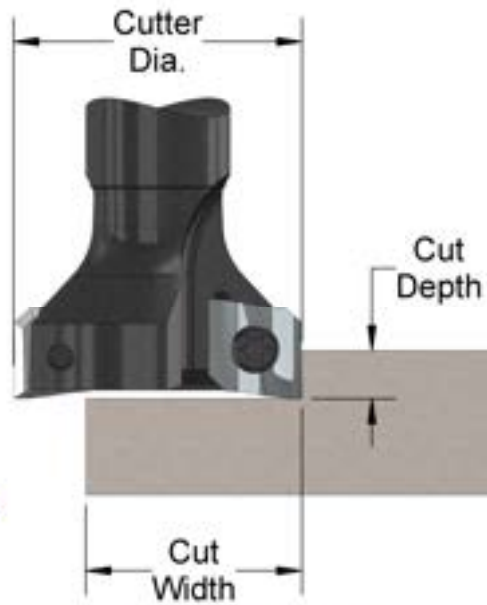

See back cover for all shank style Shear-Hogs.

Test No.	Cutter	Cutter Dia.	RPM	Cut Width	Cut Depth	IPM Feed	No. Flutes	IPT Chip	CIM
1.	SH125	1.25	6500	1.25	.125	275	2	.027	42
2.	SH125	1.25	6500	1.0	.250	375	2	.037	47
3.	SH200	2.0	6500	2.0	.250	75	3	.004	37

All tests were run on a recent model Haas VF1 based on the highest Inches Per Minute possible with the load meter showing 100%. Haas estimates 7.5 actual spindle HP at 6500 RPM.

When calculating speeds and feeds for Shear-Hogs we aim for 6 CIM per horse power at the spindle. Please see the sample calculation below.

Given: 10 HP at the spindle, 6,500 RPM, Cut width 3.5", (4) flutes, and Cut depth of .100"

Stock Removal (CIM)...  $HP \times 6$ .....10 X 6..... 60 CIM  
 SFM.....  $RPM \times .262 \times Tool\ Dia$ .....6,500 X .262 X 3.5..... 5,960 SFM  
 IPM.....  $CIM / (Cut\ Width \times Cut\ Depth)$ .....60 / (3.5 X .100)..... 171 IPT  
 IPT.....  $IPM / (RPM \times No.\ of\ Teeth)$ .....171 / (6,500 X 4)..... .0066 IPT



A. B. TOOLS, INC.  
 1051 Aviation Blvd.  
 Lincoln, CA 95648-9312

Phone 916 408-2442  
 FAX 916 993-3949

www.abtoolsinc.com  
 E-Mail: mail@abtoolsinc.com



**NEW !!!**

# Shell Mill Arbors

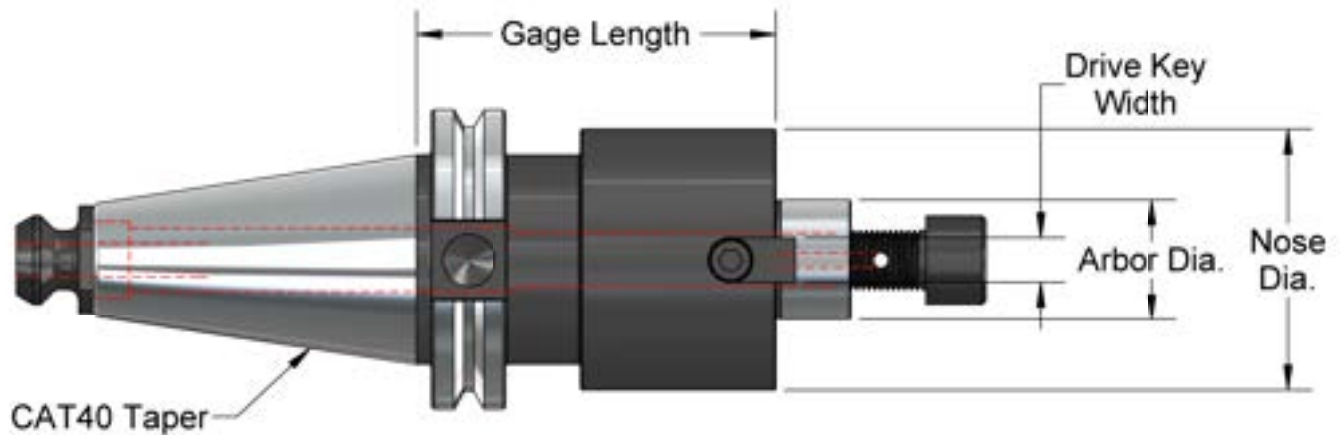
**NEW !!!**

Concentricity better than .0002 at face and arbor

Made from Alloy Steel Rc 54 - 56

Removable drive keys

No.	Arbor Dia.	Nose Dia.	Gage Length	Drive Key Width	Shell Shear-Hog	Price
CAT40-FMA.500-2.0	.500	1.74	2.0	.249	Shell 200	<b>\$125.</b>
CAT40-FMA.750-1.5	.750	1.76	1.5	.312	Shell 250	<b>\$140.</b>
CAT40-FMA.750-1.5	.750	1.76	1.5	.312	Shell 275	<b>\$140.</b>
CAT40-FMA1.0-3.0	1.00	2.18	3.0	.370	Shell 300	<b>\$160.</b>
CAT40-FMA1.25-1.5	1.25	2.49	1.5	.495	Shell 400	<b>\$125.</b>
CAT40-FMA1.5-1.5	1.50	2.49	1.5	.620	Shell 500	<b>\$125.</b>
CAT40-FMA1.5-1.5	1.50	2.49	1.5	.620	Shell 600	<b>\$125.</b>
CAT40-FMA1.5-1.5	1.50	2.49	1.5	.620	Shell 700	<b>\$125.</b>

Thru Coolant Arbor Screws		
Size	Shell Shear-Hog	Price
1/4-28	SHELL 200	<b>\$7.50</b>
3/8-24	SHELL 250	<b>\$7.50</b>
3/8-24	SHELL 275	<b>\$7.50</b>
1/2-20	SHELL 300	<b>\$8.75</b>
5/8-18	SHELL 400	<b>\$11.00</b>
3/4-16	SHELL 500	<b>\$12.50</b>
3/4-16	SHELL 600	<b>\$12.50</b>
3/4-16	SHELL 700	<b>\$12.50</b>

Thru Coolant Retention Knob	
No.	Price
PS-11122	<b>\$18.</b>



A. B. TOOLS, INC.  
1051 Aviation Blvd.  
Lincoln, CA 95648-9312

Phone 916 408-2442  
FAX 916 993-3949

www.abtoolsinc.com  
E-Mail: mail@abtoolsinc.com

# Shell Shear-Hogs®

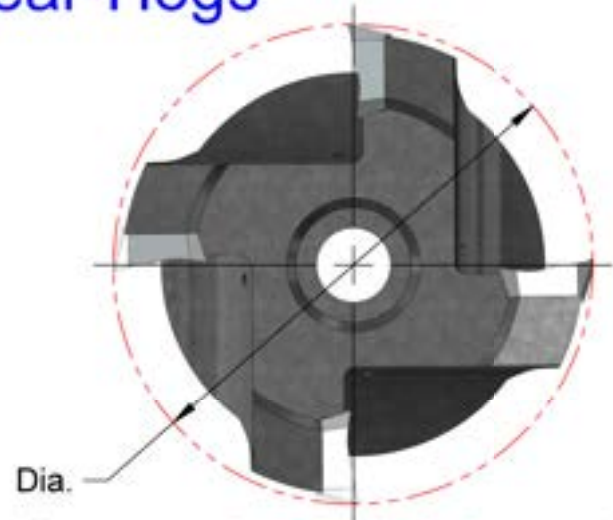
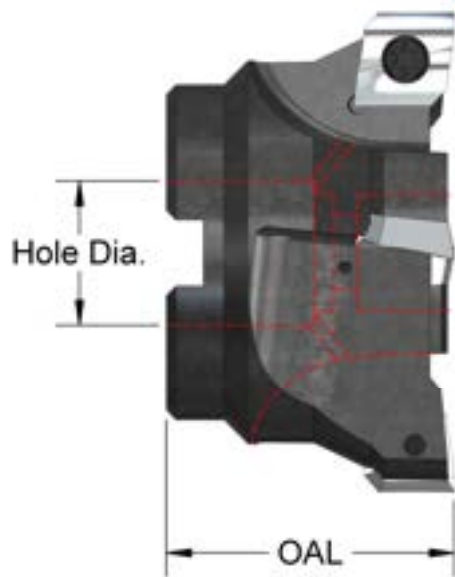

**All cutter prices include inserts, insert screws, coolant screw and wrench**

Number	Dia.	Hole Dia.	OAL	No. of Flutes	Price Incl. Inserts	Coolant Screws	
						Size	Price
SHELL 200	2.0	.500	1.25	2 or 3	<b>\$430.</b>	1/4-28	<b>\$7.50</b>
SHELL 250	2.5	.750	1.50	4	<b>\$475.</b>	3/8-24	<b>\$7.50</b>
SHELL 275	2.75	.750	1.50	4	<b>\$510.</b>	3/8-24	<b>\$7.50</b>
SHELL 300	3.0	1.00	1.75	4	<b>\$540.</b>	1/2-20	<b>\$8.75</b>
SHELL 400	4.0	1.25	1.87	4	<b>\$630.</b>	5/8-18	<b>\$11.00</b>
SHELL 500	5.0	1.50	2.25	5	<b>\$750.</b>	3/4-16	<b>\$12.50</b>
SHELL 600	6.0	1.50	2.25	6	<b>\$1000.</b>	3/4-16	<b>\$12.50</b>
SHELL 700	7.0	1.50	2.25	8	<b>\$1500.</b>	3/4-16	<b>\$12.50</b>

You may use Std. Socket Head screws without thru-tool coolant. Or, use our modified screws with coolant holes

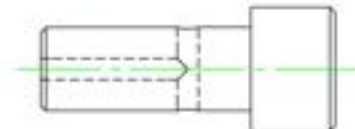

Shear-Hog Inserts	Corner	Price
ADEH-430	Sharp	<b>\$19.50 ea.</b>
ADEH-431	.010 R	<b>\$19.50 ea.</b>
ADEH-432	.030 R	<b>\$19.50 ea.</b>
ADEH-434	.060 R	<b>\$19.50 ea.</b>
ADEH-436	.090 R	<b>\$21.50 ea.</b>
ADEH-438	.120 R	<b>\$21.50 ea.</b>
ADEH-45	.015 x 45°	<b>\$21.50 ea.</b>

Extra Insert Features	Add to Price
.002 Honed Edge	<b>\$3.00</b>
AlTiN Coat	<b>\$4.25</b>
DLC Coat	<b>\$5.75</b>
Honed Edge & AlTiN Coat	<b>\$7.25</b>
Insert Screws and Wrench	
3.5mm-SH (2012 and newer)	<b>\$2.00 ea.</b>
8-32-SH (Older than 2012)	<b>\$2.00 ea.</b>
T15 Wrench	<b>\$7.50 ea.</b>



A. B. TOOLS, INC.  
1051 Aviation Blvd.  
Lincoln, CA 95648-9312

Phone 916 408-2442  
FAX 916 993-3949

www.abtoolsinc.com  
E-Mail: mail@abtoolsinc.com

# T-Slot Shear-Hogs®

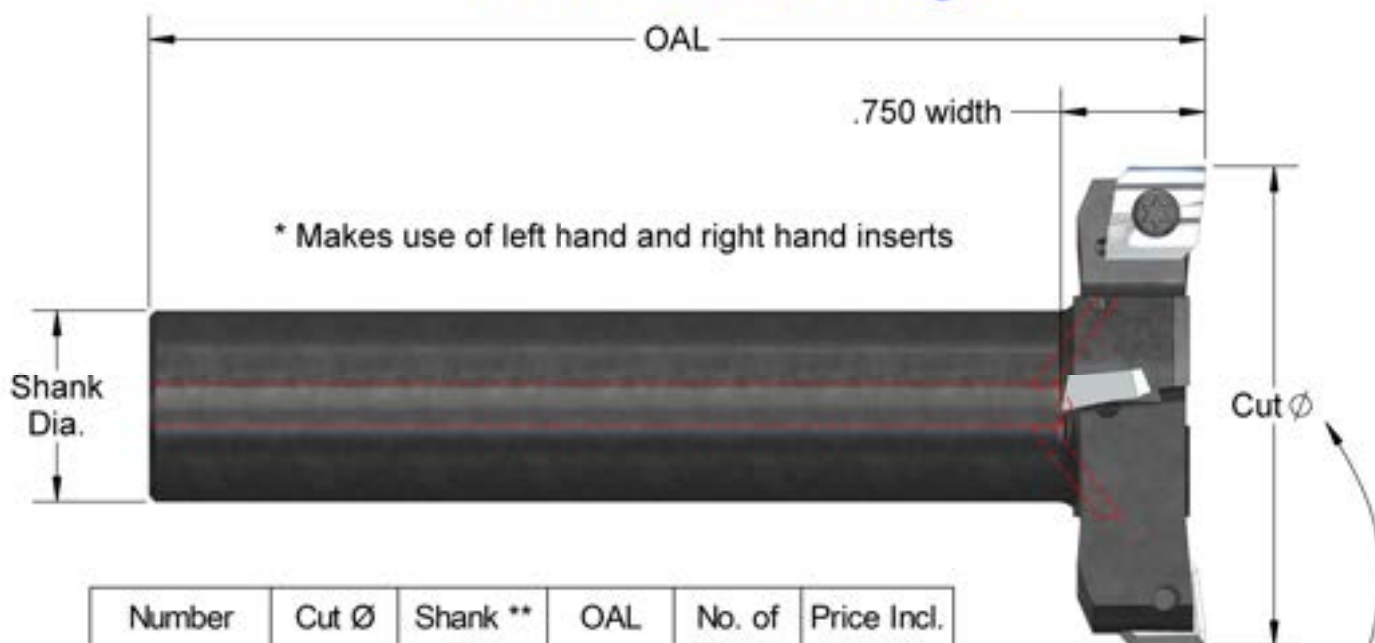

Number	Cut Ø	Shank ** Dia.	OAL	No. of Flutes	Price Incl. Inserts
TS 150	1.50	3/4	4.5	2	<b>\$445.</b>
TS 175	1.75	3/4	5.5	2	<b>\$475.</b>
TS 200	2.00	1.0	6	2	<b>\$520.</b>
TS 250	2.50	1.0	5.5	4	<b>\$550.</b>
TS 325	3.25	1-1/4	6	4	<b>\$675.</b>
TS 400	4.00	1-1/4	7	4	<b>\$775.</b>
TS 450	4.50	1-1/4	7	6	<b>\$825.</b>

Cutting diameters are not for finish profiling with T-Slot Shear-Hogs.

Inserts can be spun ground in T-Slot Shear-Hogs to cut straight in that tool only at an additional charge.

\*\* We can modify shanks to smaller sizes.  
Price & lead time based on specific request.

## LH/RH Inserts same price



Shear-Hog Inserts	Corner	Price
ADEH-430	Sharp	<b>\$19.50 ea.</b>
ADEH-431	.010 R	<b>\$19.50 ea.</b>
ADEH-432	.030 R	<b>\$19.50 ea.</b>
ADEH-434	.060 R	<b>\$19.50 ea.</b>
ADEH-436	.090 R	<b>\$21.50 ea.</b>
ADEH-438	.120 R	<b>\$21.50 ea.</b>
ADEH-45	.015 x 45°	<b>\$21.50 ea.</b>

Extra Insert Features	Add to Price
.002 Honed Edge	<b>\$3.00</b>
AlTiN Coat	<b>\$4.25</b>
DLC Coat	<b>\$5.75</b>
Honed Edge & AlTiN Coat	<b>\$7.25</b>
Insert Screws and Wrench	
3.5mm-SH (2012 and newer)	<b>\$2.00 ea.</b>
8-32-SH (Older than 2012)	<b>\$2.00 ea.</b>
T15 Wrench	<b>\$7.50 ea.</b>



A. B. TOOLS, INC.  
1051 Aviation Blvd.  
Lincoln, CA 95648-9312

Phone 916 408-2442  
FAX 916 993-3949

www.abtoolsinc.com  
E-Mail: mail@abtoolsinc.com

# Shank Style Shear-Hogs®

The Shear-Hogs have no set-screw flats for possible shrink fit use or balancing. We will mill flats per request at no charge.

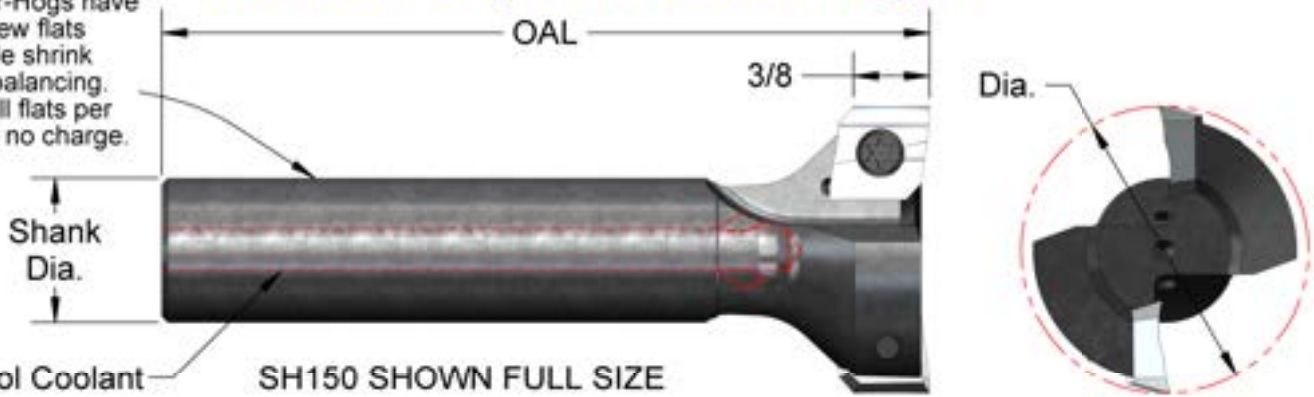

Thru Tool Coolant SH150 SHOWN FULL SIZE

## Are you rough milling aluminum at 6 CIM per HP?

Number	Dia.	Shank Dia.	OAL	No. of Flutes	Ramp Angle	Price	Shear-Hog Inserts	Corner	Price
SH100	1.0	3/4	4.0	1	Drills in Z!	\$215.	ADEH-430	Sharp	\$19.50 ea.
SH100-6	1.0	3/4	6.0	1	Drills in Z!	\$265.	ADEH-431	.010 R	\$19.50 ea.
SH125	1-1/4	3/4	4.0	2	8°	\$245.	ADEH-432	.030 R	\$19.50 ea.
SH125-1	1-1/4	1.0	4.0	2	8°	\$255.	ADEH-434	.060 R	\$19.50 ea.
SH125-6	1-1/4	1.0	6.0	2	8°	\$330.	ADEH-436	.090 R	\$21.50 ea.
SH125-9	1-1/4	1.0	9.0	2	8°	\$435.	ADEH-438	.120 R	\$21.50 ea.
SH150	1-1/2	3/4	4.0	2	5°	\$285.	ADEH-45	.015 x 45°	\$21.50 ea.
SH150-1	1-1/2	1.0	4.5	2	5°	\$295.			
SH150-7	1-1/2	1-1/4	7.0	2	5°	\$365.	Extra Insert Features Add to Price		
SH150-8	1-1/2	1.0	8.0	2	5°	\$395.	.002 Honed Edge \$3.00		
SH200-3/4	2.0	3/4	4.5	3	4°	\$340.	ATiN Coat \$4.25		
SH200-1	2.0	1.0	5.0	3	4°	\$340.	DLC Coat \$5.75		
SH200-7	2.0	1-1/4	7.0	3	4°	\$410.	Honed Edge & ATiN Coat \$7.25		
SH200-9	2.0	1-1/4	9.0	3	4°	\$465.	Insert Screws and Wrench		
SH300-3/4	3.0	3/4	5.0	4	None	\$455.	3.5mm-SH (2012 and newer) \$2.00 ea.		
SH300-1	3.0	1.0	5.0	4	None	\$455.	8-32-SH (Older than 2012) \$2.00 ea.		
SH300-1.25	3.0	1-1/4	5.0	4	None	\$455.	T15 Wrench \$7.50 ea.		
SH400-1.25	4.0	1-1/4	5.5	4	None	\$600.			
SH450	4-1/2	1-1/4	5.5	5	None	\$675.			

All cutter prices include Inserts, Screws, and Wrench, assembled and ready to cut.

See page 63 for recent test results on a HAAS VF1



A. B. TOOLS, INC.  
1051 Aviation Blvd.  
Lincoln, CA 95648-9312

Phone 916 408-2442  
FAX 916 993-3949

www.abtoolsinc.com  
E-Mail: mail@abtoolsinc.com